

GENERAC[®]

POWER SYSTEMS, INC.

Owner's Manual and Installation Instructions

Liquid-cooled Recreational Vehicle Generator

- Model: 04270-0
QUIETPACT™ 75D

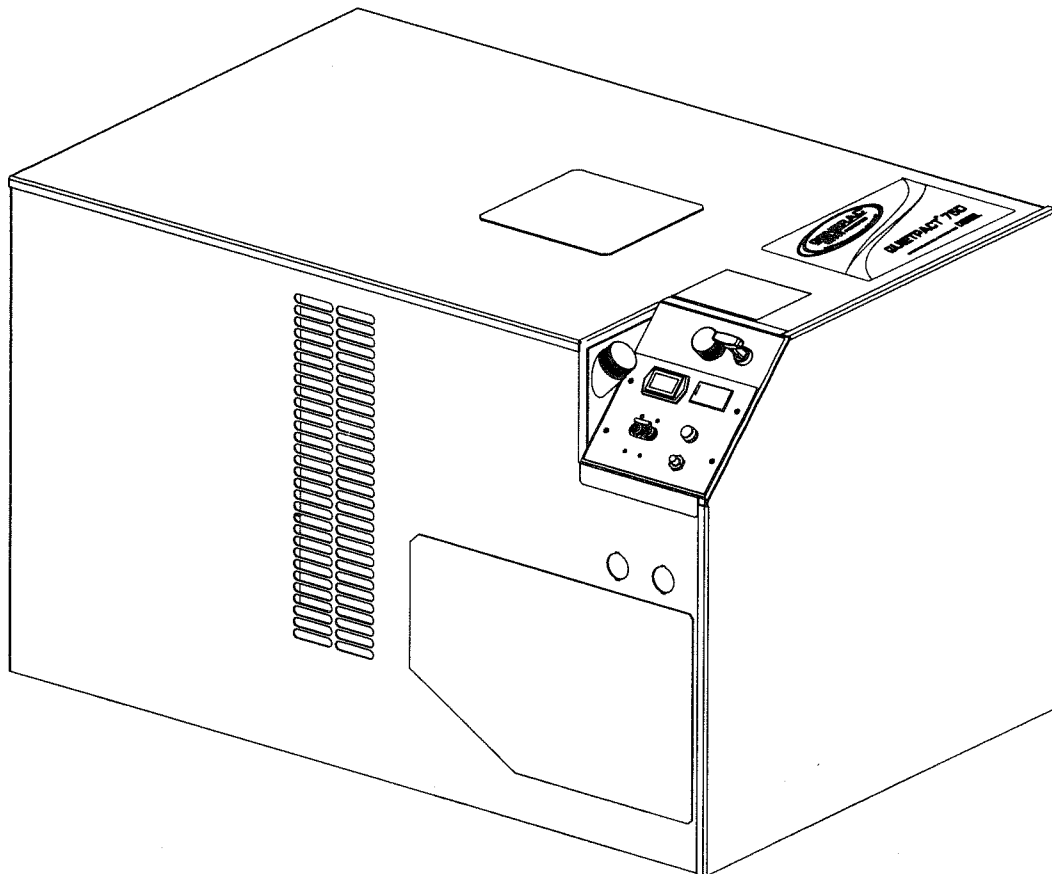

INTRODUCTION

Thank you for purchasing this model of the QUIETPACT™ product line by Generac Power Systems Inc. This model is designed and manufactured to supply electrical power for recreational vehicles.

◆ READ THIS MANUAL THOROUGHLY

If you do not understand any portion of this manual, contact Generac or your nearest Generac Authorized Service Dealer for starting, operating and servicing procedures.

Throughout this publication, and on tags and decals affixed to the generator, DANGER, WARNING, CAUTION and NOTE blocks are used to alert you to special instruction about a particular operation that may be hazardous if performed incorrectly or carelessly. Observe them carefully. Their definitions are as follows:



After this heading, you can read instructions that, if not strictly complied with, will result in personal injury or property damage.



After this heading, you can read instructions that, if not strictly complied with, may result in personal injury or property damage.



After this heading, you can read instructions that, if not strictly complied with, could result in damage to equipment and/or property.

NOTE:

After this heading, you can read explanatory statements that require special emphasis.

These safety warnings cannot eliminate the hazards that they indicate. Common sense and strict compliance with the special instructions while performing the service are essential to preventing accidents.

Four commonly used safety symbols accompany the DANGER, WARNING and CAUTION blocks. The type of information each indicates follows:

 This symbol points out important safety information that, if not followed, could endanger personal safety and/or property of you and others.

 This symbol points out potential explosion hazard.

 This symbol points out potential fire hazard.

 This symbol points out potential electrical shock hazard.

The operator (driver) is responsible for proper and safe use of the vehicle and its equipment, and the safety of all vehicle occupants. We strongly recommend that the operator read this manual and thoroughly understand all instructions before using this equipment. We also strongly recommend instructing other occupants in the vehicle to properly start and operate the generator. This prepares them if they need to operate the equipment in an emergency.

◆ CONTENTS

This manual contains pertinent owner's information, including warranty, electrical diagrams, exploded views and lists of repair parts for generator model number 04270-0. In addition, the latter portion of this manual contains information necessary for the proper installation of these generators.

◆ OPERATION AND MAINTENANCE

It is the operator's responsibility to perform all safety checks, to make sure that all maintenance for safe operation is performed promptly, and to have the equipment checked periodically by a Generac Authorized Service Dealer. Normal maintenance service and replacement of parts are the responsibility of the owner/operator and, as such, are not considered defects in materials or workmanship within the terms of the warranty. Individual operating habits and usage contribute to the need for maintenance service.

Proper maintenance and care of your generator ensure a minimum number of problems and keep operating expenses at a minimum. See your Generac Authorized Service Dealer for service aids and accessories.

◆ HOW TO OBTAIN SERVICE

When your generator requires servicing or repairs, simply contact a Generac Authorized Service Dealer for assistance. Service technicians are factory-trained and are capable of handling all of your service needs.

When contacting a Generac Authorized Service Dealer or the factory about parts and service, always supply the complete model number and serial number of your unit as given on its data decal, which is located on your generator.

Model No. _____ Serial No. _____

AUTHORIZED SERVICE DEALER LOCATION

To locate the GENERAC AUTHORIZED SERVICE
DEALER nearest you, please call this number:

1-800-333-1322

ONLY DEALER LOCATION INFORMATION
CAN BE OBTAINED AT THIS NUMBER.

Part I – Owner’s Manual

Introduction	Inside Front Cover
Read This Manual Thoroughly	IFC
Contents	IFC
Operation and Maintenance	IFC
How to Obtain Service.....	IFC
Authorized Service Dealer Locator Number	IFC
Safety Rules	2
Section 1 – General Information	4
1.1 Generator Identification.....	4
1.2 Generator Applicability	5
1.3 Safety.....	5
1.4 Generator AC Connection System	5
1.5 Specifications	5
1.5.1 Fuel Requirements.....	5
1.5.2 Fuel Consumption	6
1.5.3 Engine Oil Requirements.....	6
1.5.4 Coolant	6
1.5.5 Engine	6
1.5.6 Generator	6
Section 2 – Operation	7
2.1 Generator Control Panel	7
2.1.1 Hourmeter	7
2.1.2 Start/Stop Switch.....	7
2.1.3 Fuse.....	7
2.1.4 Line Breaker	7
2.1.5 Preheat Switch.....	7
2.2 Optional Remote Start/Stop	7
2.3 Before Starting the Engine.....	7
2.3.1 Installation.....	7
2.3.2 Engine Lubrication.....	8
2.3.3 Fuel Supply	8
2.3.4 Coolant Level	8
2.3.5 Cooling and Ventilating Air	8
2.3.6 Engine Exhaust Gas.....	8
2.4 Starting the Generator	8
2.5 Stopping the Generator	9
2.6 Applying Loads to Generator	9
2.6.1 Letting the Engine Stabilize	9
2.6.2 Do Not Overload the Generator	9
2.7 Protection Systems.....	9
2.7.1 Low Oil Pressure Switch	9
2.7.2 High Temperature Switch	9
2.7.3 Overspeed Shutdown.....	10
2.7.4 Overvoltage Protection	10
2.8 Additional Information	10
2.8.1 25-Hour Break-in Period	10
2.8.2 25-Hour Check-up	11
2.8.3 Attention Required After Submersion	11
2.8.4 Operation in High Grass or Brush.....	11
2.8.5 Effects of Moisture and Dirt	11
Section 3 – Maintenance	12
3.1 Checking the Engine Oil Level	12
3.2 Changing the Engine Oil and/or Oil Filter	12
3.3 Servicing the Engine Air Filter	12
3.4 Spark Arrestor Muffler	13
3.5 Cleaning the Generator	13
3.6 Battery Maintenance	14
3.7 Cooling System.....	14
3.8 Engine Coolant.....	14
3.9 Major Service Manual	15
3.10 Drive Belt.....	15
3.11 Exercising the Generator	15
3.12 Out of Service Procedure	15
3.12.1 Removal From Service.....	15
3.12.2 Return to Service.....	15
3.13 Service Schedule.....	16

Part II – Installation Instructions

Safety Rules	18
Section 1 – General Information	20
1.1 Purpose and Scope of the Manual	20
1.2 Safety.....	20
1.3 Standards Booklets	20
1.4 Equipment Description	20
1.5 Generator Engine Operating Speed	20
1.6 Generator AC Connection System	20
Section 2 – Installation	22
2.1 Location and Support	22
2.1.1 Generator Location	22
2.1.2 Generator Support	22
2.1.3 Suspended Mounting.....	22
2.1.4 Generator Restraint.....	23
2.2 Generator Compartments	23
2.2.1 Compartment Construction	23
2.2.2 Sound Insulating Materials	24
2.2.3 Acoustics.....	24
2.2.4 Compartment Floor Cutouts	25
2.3 Cooling and Ventilating Air	26
2.3.1 Generator Airflow	26
2.3.2 Cooling Air Inlet Openings.....	26
2.3.3 Compensating for Restrictions.....	27
2.3.4 Testing the Installation.....	27
2.4 Diesel Fuel System.....	27
2.4.1 Fuel Tank.....	28
2.4.2 Generator Fuel Supply Line	28
2.4.2.1 Rigid Fuel Lines	28
2.4.2.2 Flexible Fuel Line	28
2.5 Exhaust System.....	29
2.5.1 Mufflers and Spark Arrestors	29
2.5.2 Exhaust System Safety.....	29
2.6 Electrical Connections	30
2.6.1 Electrical Junction Box	30
2.6.2 Wiring.....	30
2.6.3 Generator AC Connections	30
2.6.3.1 Generator Conversion to 120 Volts Only - Dual Circuits	31
2.6.4 Conduit.....	32
2.6.5 Power Supply Cord	32
2.6.6 Ground Fault Circuit Interrupters	32
2.6.7 Isolating Different Power Sources	32
2.7 Battery Installation.....	33
2.7.1 Recommended Battery.....	33
2.7.2 Battery Cables	33
2.7.3 Battery Cable Connections.....	33
2.7.4 Battery Compartment	34
2.8 Optional Accessories	34
2.8.1 Remote Start/Stop Connections	34
Section 3 – Post-installation Start-up Checks	35
3.1 Post Installation Tests	35
3.2 Before Initial Start-up	35
3.3 Initial Start	35
3.4 Testing Under Load	35
3.5 Installation Checklist	36
Appendix 1 – Troubleshooting	37
Appendix 2 – Electrical Data	38
Appendix 3 – Exploded Views and Parts Lists	40
Appendix 4 – Notes	61
Appendix 5 – Warranty	64



SAVE THESE INSTRUCTIONS - *The manufacturer suggests that these rules for safe operation be copied and posted in potential hazard areas of the recreational vehicle. Safety should be stressed to all operators and potential operators of this equipment.*

WARNING:

The engine exhaust from this product contains chemicals known to the state of California to cause cancer, birth defects or other reproductive harm.

Study these SAFETY RULES carefully before installing, operating or servicing this equipment. Become familiar with this manual and with the unit. The generator can operate safely, efficiently and reliably only if it is properly installed, operated and maintained. Many accidents are caused by failing to follow simple and fundamental rules or precautions.

Generac cannot possibly anticipate every possible circumstance that might involve a hazard. The warnings in this manual, and on tags and decals affixed to the unit, are, therefore, not all-inclusive. If you use a procedure, work method or operating technique Generac does not specifically recommend, you must satisfy yourself that it is safe for you and others. You also must make sure the procedure, work method or operating technique that you choose does not render the generator unsafe.

DANGER

Despite the safe design of this generator, operating this equipment imprudently, neglecting its maintenance or being careless can cause possible injury or death. Permit only responsible and capable persons to operate or maintain this equipment.

Parts of the generator are rotating and/or hot during operation. Exercise care near running generators.

Potentially lethal voltages are generated by these machines. Ensure all steps are taken to render the machine safe before attempting to work on the generator.

GENERAL HAZARDS

For safety reasons, Generac recommends that the installation, initial start-up and maintenance of this equipment is carried out by a Generac Authorized Service Dealer.

- The engine exhaust fumes contain carbon monoxide, which can be DEADLY. This dangerous gas, if breathed in sufficient concentrations, can cause unconsciousness or even death. This exhaust system must be installed properly, in strict compliance with applicable codes and standards. Following installation, you must do nothing that might render the system unsafe or in noncompliance with such codes and standards. The generator compartment must be completely vapor sealed from the vehicle interior. There must be no possibility of exhaust fumes entering the vehicle interior. Never operate this equipment with a leaking or defective exhaust system.
- Keep hands, feet, clothing, etc., away from drive belts, fans, and other moving or hot parts. Never remove any drive belt or fan guard while the unit is operating.
- Adequate, unobstructed flow of cooling and ventilating air is critical to correct generator operation and is required to expel toxic fumes and fuel vapors from the generator compartment. Without sufficient cooling airflow, the engine/generator quickly overheats, which causes serious damage to the generator. Do not alter the installation or permit even partial blockage of ventilation provisions, as this can seriously affect safe operation of the generator.
- When working on this equipment, remain alert at all times. Never work on the equipment when you are physically or mentally fatigued.
- Inspect the generator regularly, and contact your nearest Generac Authorized Service Dealer immediately for parts needing repair or replacement.
- Before performing any maintenance on the generator, disconnect its battery cables to prevent accidental start up. Disconnect the cable from the battery post indicated by a NEGATIVE, NEG or (-) first. Reconnect that cable last.
- Never use the generator or any of its parts as a step. Stepping on the unit can stress and break parts, and may result in dangerous operating conditions from leaking exhaust gases, fuel leakage, oil leakage, etc.
- Never insert any tool or other object through openings in the generator interior, even if the unit is not running. You might seriously injure yourself or damage the equipment.



ELECTRICAL HAZARDS

- The generator covered by this manual produces dangerous electrical voltages and can cause fatal electrical shock. Avoid contact with bare wires, terminals, connections, etc., while the unit is running. Ensure all appropriate covers, guards and barriers are in place before operating the generator. If you must work around an operating unit, stand on an insulated, dry surface to reduce shock hazard.
- Do not handle any kind of electrical device while standing in water, while barefoot, or while hands or feet are wet. **DANGEROUS ELECTRICAL SHOCK MAY RESULT.**
- During installation onto the vehicle, have the generator properly grounded (bonded) either by solid mounting to the vehicle frame or chassis, or by means of an approved bonding conductor. **DO NOT** disconnect the bonding conductor, if so equipped. **DO NOT** reconnect the bonding conductor to any generator part that might be removed or disassembled during routine maintenance. If the grounding conductor must be replaced, use only a flexible conductor that is of No. 8 American Wire Gauge (AWG) copper wire minimum.
- In case of accident caused by electric shock, immediately shut down the source of electrical power. If this is not possible, attempt to free the victim from the live conductor. **AVOID DIRECT CONTACT WITH THE VICTIM.** Use a nonconducting implement, such as a dry rope or board, to free the victim from the live conductor. If the victim is unconscious, apply first aid and get immediate medical help.
- Never wear jewelry when working on this equipment. Jewelry can conduct electricity resulting in electric shock, or may get caught in moving components causing injury.

FIRE HAZARDS

- For fire safety, the generator must be installed and maintained properly. Installation must always comply with ANSI 119.2-1975/NFPA 501C-1974, "Standard for Recreational Vehicles, Part III - Installation of Electrical Systems," along with all applicable codes, standards, laws and regulations. Adhere strictly to local, state and national electrical and building codes. Comply with regulations the Occupational Safety and Health Administration (OSHA) has established. Also, ensure that the generator is installed in accordance with the manufacturer's instructions and recommendations. Following proper installation, do nothing that might alter a safe installation and render the unit in noncompliance with the aforementioned codes, standards, laws and regulations.
- Keep a fire extinguisher in the vehicle at all times. Extinguishers rated "ABC" by the National Fire Protection Association are appropriate for use on the recreational vehicle generator electrical system. Keep the extinguisher properly charged and be familiar with its use. If you have any question pertaining to fire extinguishers, consult your local fire department.

EXPLOSION HAZARDS

- Do not smoke around the generator. Wipe up any fuel or oil spills immediately. Ensure that no combustible materials are left in the generator compartment, or on or near the generator, as **FIRE** or **EXPLOSION** may result. Keep the area surrounding the generator clean and free from debris.
- All fuel types are potentially **FLAMMABLE** and/or **EXPLOSIVE** and should be handled with care. Comply with all laws regulating the storage and handling of fuels. Inspect the unit's fuel system frequently and correct any leaks immediately. Fuel supply lines must be properly installed, purged and leak tested according to applicable fuel-gas codes before placing this equipment into service.

1.1 GENERATOR IDENTIFICATION

Please record the following information from the generator DATA DECAL or information decal, located below the user control panel.

- | | |
|-----------------------|------------------------|
| 1. Model Number _____ | 2. Serial Number _____ |
| 3. kW Rating _____ | 4. Rated Voltage _____ |

**Model: 04270-0
QUIETPACT™ 75D**

1. 2-Pole, 35-amp Circuit Breaker
2. Hourmeter
3. Oil Fill Opening and Plug
4. Oil Dipstick
5. Engine Start/Stop Switch
6. 14-amp Fuse
7. Engine Preheat Switch
8. Fuel Filter
9. Air Filter
10. Oil Filter
11. Starter Motor
12. Preheat Contactor
13. Starter Contactor
14. Radiator
15. Coolant Recovery Tank
16. Muffler
17. Battery Connections
18. Fuel Connections
19. Alternator
20. Fuel Pump
21. Centrifugal Cooling Fan and Housing
22. Alternator Drive Belt
23. Alternator Drive Belt Tensioner
24. Cooling Fan Drive Belt
25. Cooling Fan Drive Belt Tensioner
26. Engine

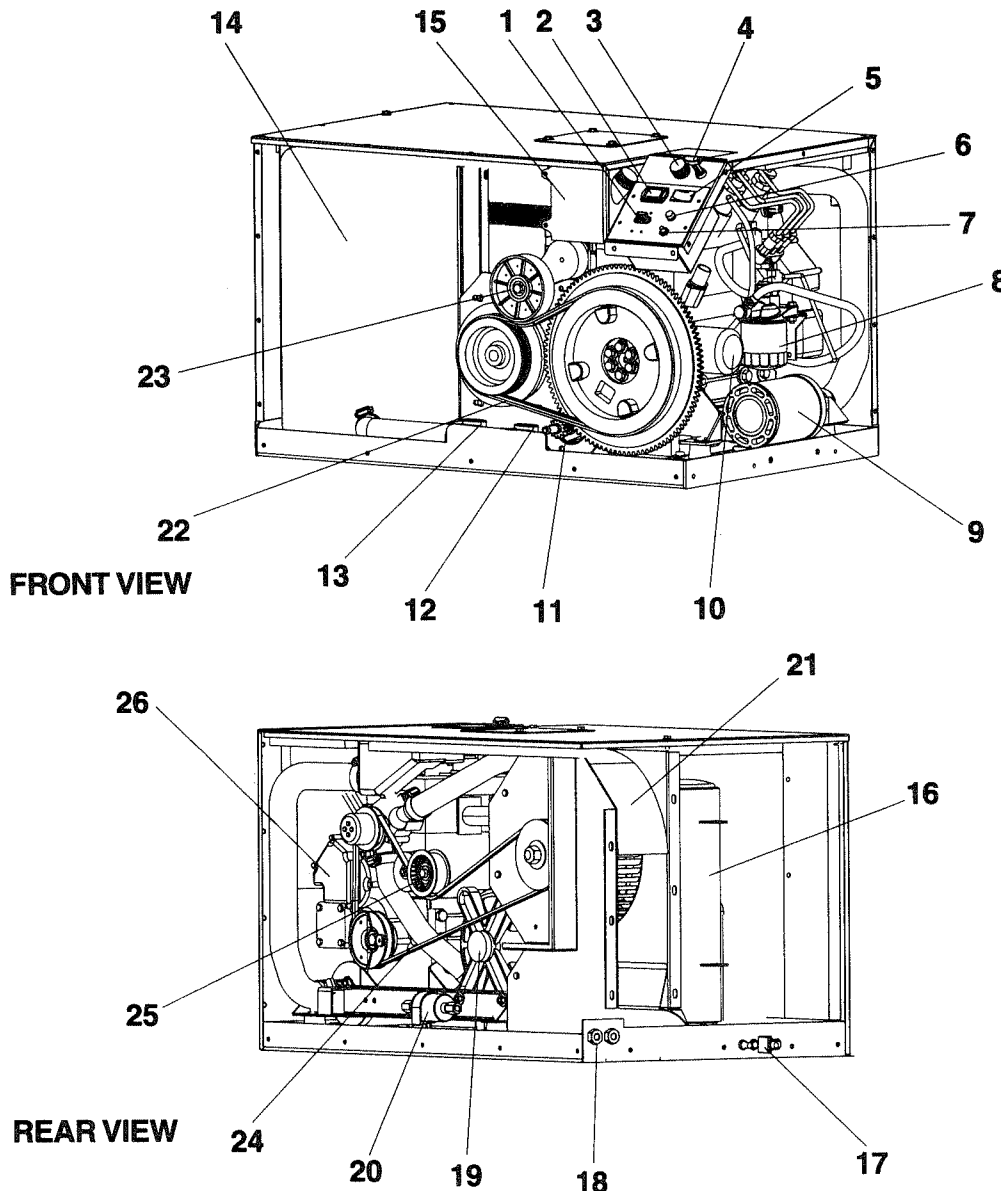

1.2 GENERATOR APPLICABILITY

These generators have been designed and manufactured for supplying electrical power for recreational vehicles. You should not modify the generator or use it for any application other than for what it was designed. If there are any questions pertaining to its application, write or call the factory. Do not use the unit until you have been advised by a competent authority.

▲ DANGER ▲

▲ For fire safety, the generator must have been properly installed in compliance with ANSI 119.2-1975/NFPA 501C-1974, "Standard for Recreational Vehicles, Part III – Installation of Electrical Systems." The generator also must have been installed in strict compliance with the manufacturer's detailed installation instructions. After installation, do nothing that might render the unit in noncompliance with such codes, standards and instructions.

You can use this generator to supply electrical power for operating 120/240-volt, single-phase, 60 Hertz, AC electrical loads. These loads can require up to 7,500 watts (7.5 kW) of power, but cannot exceed 62.5 AC amps of current at 120 volts, or 31.2 AC amps at 240 volts.

▲ CAUTION ▲

▲ Do not overload the generator. Some installations may require that electrical loads be alternated to avoid overloading. Applying excessively high electrical loads may damage the generator and may shorten its life. Add up the rated watts of all electrical lighting, appliance, tool and motor loads the generator will power at one time. This total should not be greater than the wattage capacity of the generator. If an electrical device nameplate gives only volts and amps, multiply volts times amps to obtain watts (volts x amps = watts). Some electric motors require more watts of power (or amps of current) for starting than for continuous operation.

1.3 SAFETY

Before attempting to use the generator set, carefully read the "Safety Rules" section of this manual. Comply strictly with these rules to prevent accidents and damage to equipment and/or property. We suggest copying and posting the "Safety Rules" in potential hazard areas of the vehicle. Stress safety to all operators and potential operators of this equipment.

1.4 GENERATOR AC CONNECTION SYSTEM

This generator is equipped with dual stator AC power windings. These two-stator windings supply electrical power to customer electrical loads by means of a dual two-wire connection system. Note, however, that the neutral is grounded.

The generator may have been installed so that it powers 120- and/or 240-volt AC electrical loads (Figure 1.1). It can be rewired to connect 120-volt AC electrical loads only. This procedure should be done by a Generac Authorized Service Dealer or other qualified installer. Refer to the installation portion of this manual for more information.

Figure 1.1 – Connections for 120/240 Dual Voltage

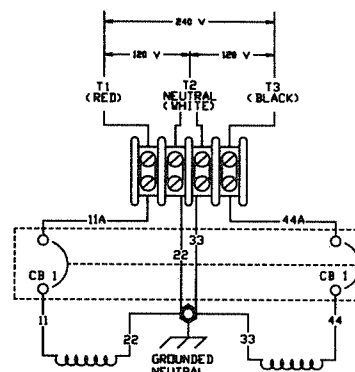

1.5 SPECIFICATIONS

◆ 1.5.1 FUEL REQUIREMENTS

The generator is equipped with a diesel fuel system. Use clean, fresh No. 1D or No. 2D diesel fuel with minimum Cetane number of 40. It also must conform to American Society of Testing and Materials (ASTM) specifications. Never use any dirty or contaminated fuel. When adding fuel, DO NOT overfill the tank. Allow room at the top of the tank for fuel expansion. Depending on the installation, the generator may have either a separate fuel tank, or it may "share" the vehicle engine's fuel tank.

NOTE:

Some installations using a "shared" fuel tank may have a generator fuel pickup tube that is shorter than the vehicle engine's pickup tube. Such an arrangement causes the generator engine to "run out of gas" while adequate fuel for the vehicle remain in the tank.

Also, appropriate care should be taken in applications where extremely low ambient temperatures are possible to ensure the temperature of the diesel fuel is not allowed to fall below levels where "gelling" could occur.

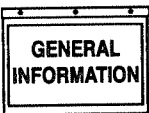

Section 1 – General Information
QUIETPACT™ 75D Recreational Vehicle Generator

◆ **1.5.2 FUEL CONSUMPTION (GAL/HR)**

Model	No Load	Half Load	Full Load
QUIETPACT™ 75D (04270-0)	0.28	0.45	0.78

◆ **1.5.3 ENGINE OIL REQUIREMENTS**

Use a high-quality detergent oil with American Petroleum Institute (API) classification "For Service CC." Detergent oils keep the engine cleaner and reduce carbon deposits. Use oil having the following SAE viscosity rating, based on the ambient temperature range anticipated before the next oil change:

Temperature	Oil Grade (Recommended)
Above 100° F (38° C)	SAE 15W-40 or SAE 40
40° to 100° F (4.4° to 38° C)	SAE 10W-30 or SAE 30
Below 40° F (4.4° C)	SAE 5W-20 or 5W-30

Crankcase and oil filter capacity is approximately 3.5 L or 3.7 U.S. quarts. Do NOT use special additives. See Sections 3.1 and 3.2 (Page 12) for oil level checking and changing procedures.

◆ **1.5.4 COOLANT**

Use a mixture of half low silicate, ethylene glycol base antifreeze and half soft water. Use only soft water and only low silicate antifreeze. If desired, you may add a high quality rust inhibitor to the recommended coolant mixture. When adding coolant, always add the recommended 50-50 mixture.



▲ Do not remove the radiator pressure cap while the engine is hot or serious burns from boiling liquid or steam could result.

▲ Ethylene glycol base antifreeze is poisonous. Do not use your mouth to siphon coolant from the radiator, recovery bottle or any container. Wash your hands thoroughly after handling. Never store used antifreeze in an open container because animals are attracted to the smell and taste of antifreeze even though it is poisonous to them.



▲ Do not use any chromate base rust inhibitor with ethylene glycol base antifreeze, or chromium hydroxide ("green slime") will form and cause overheating. Engines that have been operated with a chromate base rust inhibitor must be chemically cleaned before adding ethylene glycol base antifreeze. Using any high silicate antifreeze boosters or additives also will cause overheating. We also recommend that you DO NOT use any soluble oil inhibitor for this equipment.

◆ **1.5.5 ENGINE**

Type of Engine	ISM Diesel
Cylinder Arrangement	3, in-line
Displacement	58.2 in. (954 cc)
Bore	2.95 in. (75 mm)
Stroke	2.83 in. (72 mm)
Compression Ratio	23-to-1
Combustion Chamber Type	Pre-Combustion
Rated Horsepower	13 @ 1,950 rpm
Cylinder Block	Cast Iron
Number of Main Bearings	4
Number of Teeth on Flywheel	104
Type of Governor	Mechanical, Fixed Speed
Fuel Filter	Full Flow Spin-On (Part # 69858)
Oil Filter	Full Flow with Bypass Valve (Part # 126-70939)
Oil Pressure	29-71 psi
Type of Cooling System	Pressurized, Closed Recovery
Cooling Method	Liquid-cooled
Type of Cooling Fan	Centrifugal Puller
Cooling System Capacity	1.4 U.S. gals (5.3 L)
Air Cleaner	Disposable Filter (Part # C4880)
Starter	12-volt DC Electric
Recommended Battery	70 Ah, 360 Cold-cranking Amps
Maximum Cranking Current	220 Amps
Ground Polarity	Negative

◆ **1.5.6 GENERATOR**

Rated Maximum Continuous AC Output at ...	
85° F (29° C) Ambient	7,500 Watts (7.5 kW)
100° F (38° C) Ambient	7,000 Watts (7.0 kW)
120° F (49° C) Ambient	6,000 Watts (6.0 kW)
Rated Voltage	120/240 Volts AC*
Rated Maximum Continuous AC Current at ...	
7,500 Watts	
120 Volts	62.5 Amps
240 Volts	31.2 Amps
7,000 Watts	
120 Volts	58.3 Amps
240 Volts	29.2 Amps
6,000 Watts	
120 Volts	50.0 Amps
240 Volts	25.0 Amps
Phase	Single
Rotor Speed at No Load	3,780 rpm
Number of Rotor Poles	2
Engine RPM	1,950
Rated AC Frequency	60 Hz
Battery Charge Voltage	14 Volts DC
Battery Charge Current	2 Amps (max)
Weight	486 Pounds
Length	36.6 inches (929 mm)
Width	23.8 inches (604 mm)
Height	22.3 inches (567 mm)

*All units are reconnectable to 120-volt-only AC output.

2.1 GENERATOR CONTROL PANEL

The following features are mounted on the generator control panel (Figure 2.1):

Figure 2.1 – Generator Control Panel

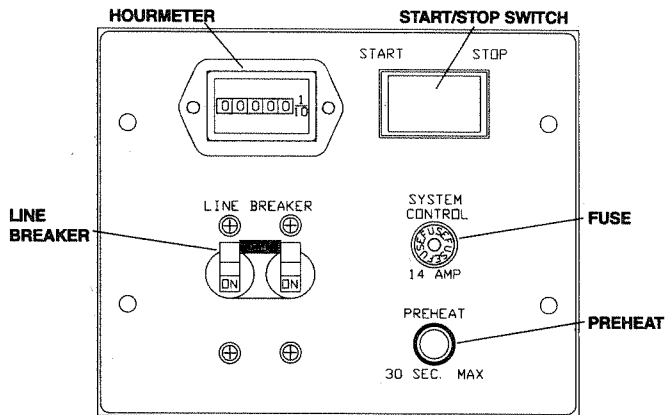

NOTE: PANEL SHOWN WITHOUT WEATHER-SEAL BOOTS.

◆ 2.1.1 HOURMETER

This indicates the time the engine-generator has operated, in hours and tenths of hours. Use the hourmeter to ensure that the periodic maintenance tasks for your generator are completed on a timely basis.

◆ 2.1.2 START/STOP SWITCH

To crank and start the engine, hold this switch in the START position. Release the switch when the engine starts. To stop an operating engine, press and hold the switch in the STOP position until the engine shuts off. The switch center position is the RUN position.

◆ 2.1.3 FUSE

The 14 amp fuse protects the engine's DC control circuit against electrical overload. If the fuse element has melted open due to overloading, the engine cannot be cranked. If you must replace the fuse, use only an identical replacement (SFE-14).



 If a fuse element melts, you should find the cause of the overload before replacing the fuse.

◆ 2.1.4 LINE BREAKER

The line (main) breaker protects the generator's AC output circuit against overload and provides a method of turning OFF the generator's 120/240-volt AC output to the vehicle circuits. The QUIETPACT™ 75D has two 35-amp breakers.

NOTE:

Refer to Section 1.4, "Generator AC Connection System," (Page 5). Individual installations will differ. If an overload occurs, the dual breakers will open the ungrounded(hot) stator leads (11 and 44). When the generator has been connected for 120 volts only, the line breakers will operate independently on the ungrounded (hot) stator leads (11 and 33).

◆ 2.1.5 PREHEAT SWITCH

The diesel engine is equipped with glow plugs, one for each cylinder. When you press the preheat switch, the glow plugs heat the engine combustion chamber for quicker starts when the engine is cold. Pressing the preheat switch also operates the fuel pump.

2.2 OPTIONAL REMOTE START/STOP

This generator is equipped with a plug-in connector which can be interfaced with an optional remote panel provided inside the vehicle. This option allows you to start and stop the generator conveniently from within the vehicle. Refer to Part II - Installation Instructions, Section 2.8 for details on the remote start/stop option.

2.3 BEFORE STARTING THE ENGINE

NOTE:

Instructions and information in this manual assume the generator has been properly installed, connected, serviced, tested and adjusted by a qualified installation technician or installation contractor.

◆ 2.3.1 INSTALLATION

Generator installation must have been properly completed so it complies with all applicable codes, standards and regulations and with the manufacturer's recommendations.



◆ 2.3.2 ENGINE LUBRICATION

Have the engine crankcase properly serviced with the recommended oil before starting. Refer to Section 1.5.3 (Page 6) and Sections 3.1 and 3.2 (Page 12) for oil servicing procedures and recommendations.



- ▲ Any attempt to crank or start the engine before you have properly serviced it with the recommended oil may result in an engine failure.

◆ 2.3.3 FUEL SUPPLY

The engine must have an adequate supply of proper fuel to operate. Before starting it, check that sufficient fuel is available.

NOTE:

Depending on the installation, the generator may have either a separate fuel tank, or it may “share” the vehicle engine’s fuel tank.

Some installations using a “shared” fuel tank may have a generator fuel pickup tube that is shorter than the vehicle engine’s pickup tube. Such an arrangement causes the generator engine to “run out of fuel” while adequate fuel for the vehicle remains in the tank.

◆ 2.3.4 COOLANT LEVEL

Check the engine coolant level prior to initial use and at recommended intervals. Refer to Section 1.5.4, “Coolant” (Page 6), and the “Maintenance” portion of this manual for procedures and recommendations.

◆ 2.3.5 COOLING AND VENTILATING AIR

Air inlet and outlet openings in the generator compartment must be open and unobstructed for continued proper operation. Without sufficient cooling and ventilating airflow, the engine/generator may overheat, which causes it to shut down and may damage the generator.

◆ 2.3.6 ENGINE EXHAUST GAS

Before starting the generator engine, you should be sure there is no way for exhaust gases to enter the vehicle interior and endanger people or animals. Close windows, doors and other openings in the vehicle that, if open, might permit exhaust gases to enter the vehicle.



- ▲ The generator engine gives off DEADLY carbon monoxide gas through its exhaust system. This dangerous gas, if breathed in sufficient concentrations, can cause unconsciousness or even death. Never operate the generator set with the vehicle inside any garage or other enclosed area. **DO NOT OPERATE THE GENERATOR IF THE EXHAUST SYSTEM IS LEAKING OR HAS BEEN DAMAGED. SYMPTOMS OF CARBON MONOXIDE POISONING ARE (a) inability to think coherently; (b) vomiting; (c) twitching muscles; (d) throbbing temples; (e) dizziness; (f) headaches; (g) weakness; and (h) sleepiness. IF YOU FEEL ANY OF THESE SYMPTOMS, MOVE INTO FRESH AIR IMMEDIATELY. IF SYMPTOMS PERSIST, GET MEDICAL HELP.**

2.4 STARTING THE GENERATOR

NOTE:

Read the vehicle manufacturer’s instructions. The owner/operator should become familiar with the vehicle in which this generator is installed. Differences exist between vehicles. For example, some vehicles may use a transfer switch to isolate dockside power from the generator, while other vehicles may use an isolating receptacle. Some vehicles may be equipped with a DC converter, which allows the generator to power certain DC lighting and other DC loads.

To start the generator from either the generator control panel or from the optional remote panel, proceed as follows:

1. Turn OFF electrical loads using the means provided in your vehicle (such as a main line circuit breaker or transfer switch).

NOTE:

If starting from the generator control panel, turn OFF loads by setting the generator’s main line breaker to the OFF (or open) position. If starting from a remote panel, turn OFF loads using the means provided in the vehicle (such as a main circuit breaker). Electrical load circuits will be turned ON after the generator has started, stabilized and warmed up.

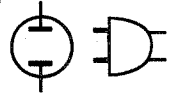

2. If the engine is cold, press the Preheat switch for 15 to 30 seconds maximum.
3. Hold the engine Start/Stop switch in the START position while pressing the Preheat switch to crank the engine. Release the switches when the engine starts.

—▲ CAUTION ▲—

▲ If the engine does not start after it has been cranking for 15 seconds, release the Start/Stop switch, wait 15 seconds, and try again. Holding the switch for longer than 15 seconds can damage the starter motor.

4. Let the engine run at no-load for a few minutes to stabilize and warm up.
5. Turn ON electrical loads using the means provided in your vehicle (such as a main line circuit breaker or transfer switch).

2.5 STOPPING THE GENERATOR

1. Turn OFF all electrical loads using the means provided in your vehicle (such as a main line circuit breaker or transfer switch).
2. Let generator run at no-load for a few minutes, to stabilize internal engine generator temperatures.

—▲ CAUTION ▲—

▲ Do not stop the engine/generator immediately after running under load. This can overheat and damage the engine and/or generator.

3. Press and hold the Start/Stop switch in the STOP position until the engine shuts off.

2.6 APPLYING LOADS TO GENERATOR

When applying electrical loads to the generator, observe these guidelines:

- Before applying electrical loads, let the generator stabilize and warm up for a minute or two.
- DO NOT overload the generator.

◆ 2.6.1 LETTING THE ENGINE STABILIZE

The generator supplies correct rated voltage only at the proper governed speed. Some electrical appliances may be extremely sensitive to voltage. Incorrect voltages can damage such appliances.

If electrical loads are applied at reduced operating speeds, such loads imposed on the engine when sufficient power is not available may shorten engine life. Never turn ON electrical loads until after the generator engine has started and stabilized at no-load.

◆ 2.6.2 DO NOT OVERLOAD THE GENERATOR

You can read the rated wattage/amperage capacity of your generator on the generator data decal located below the user control panel.

Applying electrical loads in excess of the unit's rated capacity may trip the line breaker or cause the engine/generator to shut down.

To avoid overloading, add up the wattage of all connected electrical lighting, appliance, tool and motor loads. This total should not be greater than the generator's rated wattage capacity.

- Most lighting, appliance, tool and motor loads indicate their required watts on their nameplate or data plate. For light bulbs, simply note the wattage rating of the bulb.
- If a load does not show its rated wattage, multiply that load's rated VOLTS times AMPS to obtain WATTS.
- Induction type motors (such as those that run the vehicle's furnace fan, refrigerator, air conditioner, etc.) need about 2-1/2 time more watts of power for starting than for running (for a few seconds during motor starting). Be sure to allow for this when connecting electrical loads to the generator. First, figure the watts needed to start electric motors in the system. To that figure, add the running wattages of other items that will be operated by the generator.
- Do not apply electrical loads over 75 percent of the unit's rating for the first two or three hours of operation.

2.7 PROTECTION SYSTEMS

The engine has several safety switches that cause it to automatically shut down under the following conditions: low oil pressure, high coolant temperature, and engine overspeed. See Figure 2.2 (Page 10) for the location of these devices. If automatic shut down does occur, refer to "Troubleshooting Guide" on page 39.

◆ 2.7.1 LOW OIL PRESSURE SWITCH

This switch is normally closed (N.C.) but is held open by engine oil pressure during engine running. Should operating oil pressure drop below approximately 10 psi, the switch contacts close, and the engine shuts down automatically.

◆ 2.7.2 HIGH COOLANT TEMPERATURE SWITCH

This normally open (N.O.) thermostatic switch has a sensing tip that is immersed in captive coolant. Should the coolant temperature exceed approximately 110° C (230° F), the switch contacts close, which causes the engine to shut down automatically.

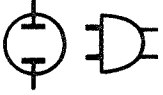

Figure 2.2 – Engine Protective Devices

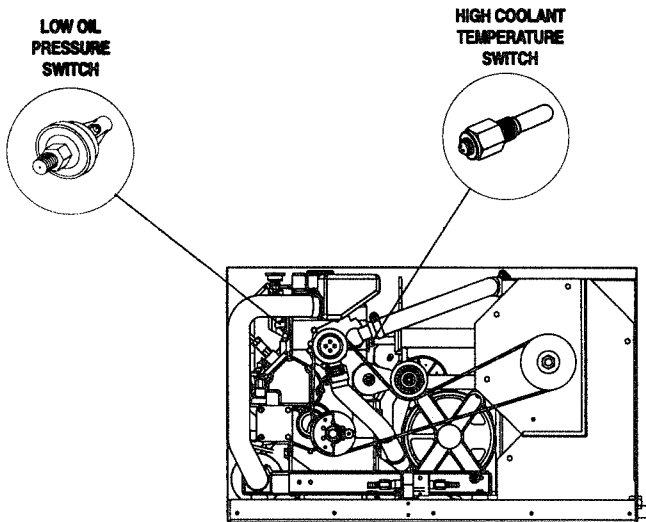
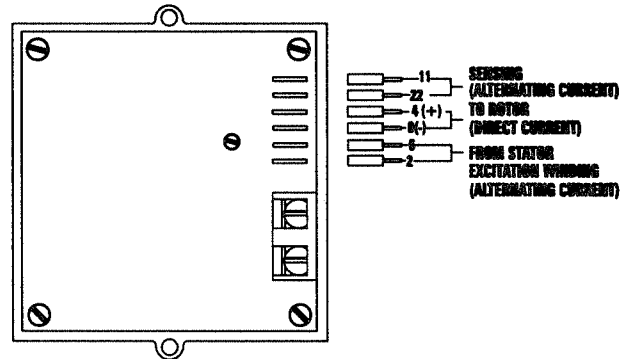

Figure 2.3 – Solid-state Voltage Regulator



The voltage regulator also incorporates a “voltage surge protection circuit.” This circuit prevents troublesome surges in the generator AC output voltage. Voltage surge is a common cause of damage to electronic equipment.

2.8 ADDITIONAL INFORMATION

◆ 2.7.3 OVERSPEED SHUTDOWN

The DC control circuit board (inside control panel) senses engine speed from the frequency of the alternator AC output. Should the alternator output frequency exceed approximately 72 Hertz (4,320 alternator rpm), circuit board action initiates an automatic engine shutdown.

◆ 2.7.4 OVERVOLTAGE PROTECTION

A solid-state voltage regulator (Figure 2.3) controls the generator’s AC output voltage. This regulator supplies an excitation current to the rotor. By regulating the rotor’s excitation current, the strength of its magnetic field is regulated and, in turn, the voltage delivered to connected electrical loads is controlled. When the AC frequency is 60 Hertz, voltage is regulated at 120 volts (voltage-to-frequency ratio is 2-to-1).

◆ 2.8.1 25-HOUR BREAK-IN PERIOD

The first 25 hours of operation is the break-in period for the generator. Properly breaking in the generator is essential to minimize oil consumption and maximize engine performance. During this 25-hour break-in period, observe the following rules:

- Run the unit at varying electrical loads to help seat the engine piston rings properly.
- After operating the unit for 25 hours, complete the tasks recommended under Section 2.8.2 (Page 11).
- For the next 75 hours of operation following the break-in period, avoid light electrical loads. Load the generator at 50 percent (or more) of its rated wattage capacity. Repeated light loads during these 75 hours can cause improper seating of engine piston rings, resulting in blowby and high oil consumption.
- Check the engine oil level frequently. Add oil if needed. It is normal for the generator engine to consume more oil than is normal until the piston rings have properly seated.

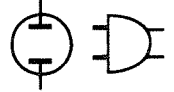

◆ 2.8.2 25-HOUR CHECK-UP

After the 25-hour break-in period, contact a Generac Authorized Service Dealer for the following maintenance. The vehicle owner is responsible for all charges:

- Change the engine crankcase oil and oil filter.
- Check all fluid levels (engine coolant, fuel, battery electrolyte fluid).
- Visually inspect the unit for any leaks or loose hardware.
- Inspect the exhaust tailpipe for any leaks or damage.

◆ 2.8.3 ATTENTION REQUIRED AFTER SUBMERSION

If the recreational vehicle generator has been submerged in water, it **MUST NOT** be started and operated. Following any submersion in water, have a Generac Authorized Service Dealer thoroughly clean and dry the generator.

◆ 2.8.4 OPERATION IN HIGH GRASS OR BRUSH

Never operate the generator while the vehicle is parked over high grass, weeds, brush, leaves or any other combustible substance. Such materials can ignite and burn from the heat of the exhaust system. The generator exhaust system becomes extremely hot during operation and remains hot for a long time after it has shut down.

◆ 2.8.5 EFFECTS OF MOISTURE AND DIRT

Keep the generator set as clean and dry as possible. Protect the unit against excessive dust, dirt, corrosive vapors, road splash, etc. Permitting dirt and moisture to accumulate on generator windings will have an adverse effect on the insulation resistance of those windings.

When moisture is allowed to remain in contact with windings, some of the moisture will be retained in voids and cracks in the insulation. This causes a reduced insulation resistance and will eventually cause problems. Dirt will make the problem worse, since dirt tends to hold moisture in contact with windings. Salt (as from sea air) also will worsen the problem since it tends to absorb moisture from the air. Salt and moisture, when combined, form a good electrical conductor.

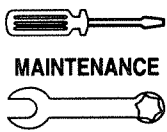

MAINTENANCE

Section 3 – Maintenance

QUIETPACT™ 75D Recreational Vehicle Generator

3.1 CHECKING THE ENGINE OIL LEVEL

After the 25-hour break-in period, check the engine crankcase oil level every eight hours of operation or at least once daily before using the generator. For oil capacities and requirements, see “Engine Oil Requirements,” Section 1.5.3 (Page 6). To check the engine oil level, proceed as follows (see Figure 3.1):

1. Be sure the generator is as level as possible.
2. Remove the dipstick and wipe it dry with a clean, lint-free cloth.
3. Install the dipstick and fully seat the T-handle; then, remove it again. The oil level should be at the dipstick “Full” mark.
4. If necessary, remove the oil fill plug and slowly add oil until it reaches the dipstick “Full” mark. **DO NOT FILL ABOVE THE “FULL” MARK.**



CAUTION

⚠ Never operate the engine with the oil level below the “Add” mark on the dipstick. Doing this could damage the engine.

5. Install the oil fill plug and the dipstick before operating the engine.

Figure 3.1 – Oil Maintenance Features

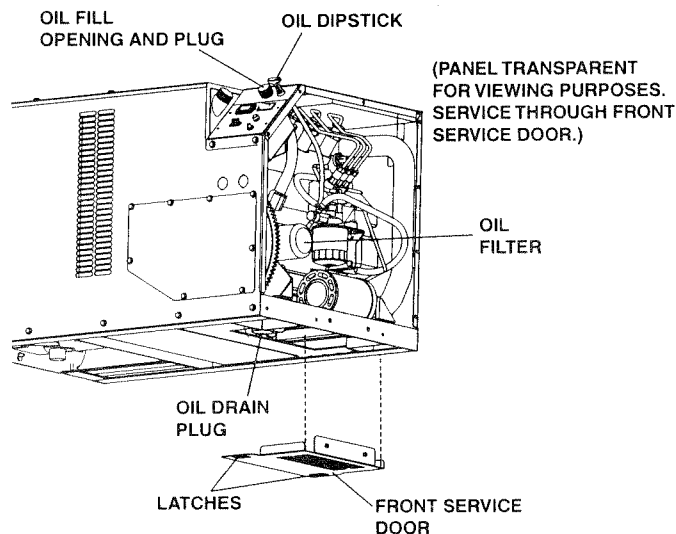

3.2 CHANGING THE ENGINE OIL AND/OR OIL FILTER

Change the engine oil and oil filter after the first 25 hours of operation (after the 25-hour break-in period, see Section 2.8.1, Page 10). See the “Service Schedule,” Section 3.13 (Page 16), for subsequent oil and filter changes. Change the oil more frequently if operating consistently under heavy load or at high ambient temperatures.

To change the oil and/or oil filter, proceed as follows (see Figure 3.1):

1. Run the engine until it is thoroughly warmed up (at least five minutes) then shut OFF the engine.
2. Immediately after the engine shuts OFF, remove the front service door located beneath the unit by retracting the two latches and pivoting the door downward.
3. Remove the air filter (see Section 3.3).
4. Remove the oil drain plug and drain the oil into a suitable container. Removing the oil fill plug will allow the crankcase to drain faster.
5. After the oil has drained, replace the oil drain plug. **GO TO STEP 8 IF CHANGING OIL ONLY.**
6. With the oil drained, remove the old oil filter by turning it counterclockwise.
7. Apply a light coating of clean engine oil to the gasket of the new filter.
8. Screw the new filter on by hand until its gasket lightly contacts the oil filter adapter. Then, tighten the filter an additional 3/4 to one turn.
9. Remove the dipstick and wipe it dry with a clean, lint-free cloth. This will be used later to check the oil level.
10. Remove the oil fill plug and slowly add the proper type and amount of recommended oil (see Section 1.5.3, Page 6). Periodically use the dipstick to check the oil level and continue to fill the crankcase until the oil reaches the dipstick “Full” mark. **DO NOT FILL ABOVE THE “FULL” MARK.**
11. Install the oil fill plug and the dipstick before operating the engine.
12. Reinstall the air filter.
13. Reattach the front service door; make sure the latches are fully engaged.
14. Start the engine and check for leaks.

NOTE:

Check the oil level and fill to the “FULL” mark after checking for leaks. The filter will retain some oil.

3.3 SERVICING THE ENGINE AIR FILTER

To access the engine air filter (Figure 3.2, Page 13), remove the front service door located beneath the unit by retracting the two latches and pivoting the door downward. Loosen the hose clamp at the base of the air filter and remove the filter. Place the hose clamp on the new filter and install it, making sure it is positioned properly before reattaching the service door. Make sure the service door latches are fully engaged.

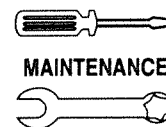

MAINTENANCE

Figure 3.2 – Engine Air Filter

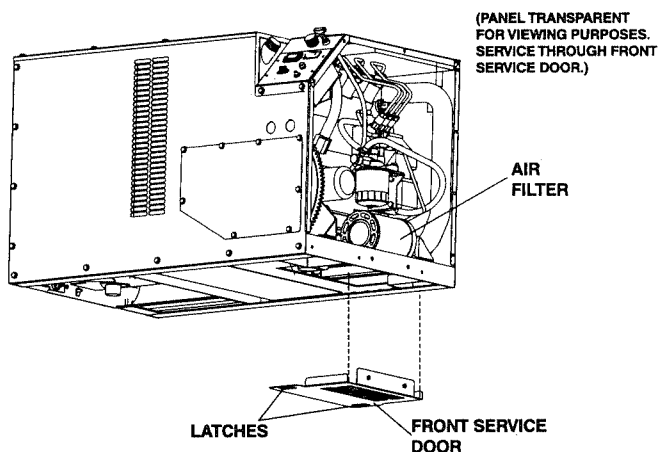

See the "Service Schedule," Section 3.13 (Page 16), for recommended air cleaner maintenance.

3.4 SPARK ARRESTOR MUFFLER

The exhaust muffler supplied with the QUIETPACT™ 75D is a spark arrestor type. Generac exhaust mufflers for recreational vehicle generators do not have a spark arrestor screen, but are of the more efficient "toroid" or "swirl" type. To remove carbon and combustion deposits from the muffler, proceed as follows (see Figure 3.3):

1. Locate the unit above a non-combustible surface and ensure that the generator exhaust piping is cool.
2. Remove the two screws holding the spark arrestor access plate to the rear floor pan.
3. Remove the spark arrestor access plate and gasket.
4. Remove the hex pipe cap from the end of the spark arrestor cleanout pipe.
5. Thread on a 3/8" NPT pipe coupling and pipe nipple to extend the cleanout pipe at least 10 inches (250 mm) below the rear floor pan; additional piping may be added to direct the muffler exhaust away from the cooling air discharge flow beneath the unit.
6. Start and run the engine for approximately 15 minutes.
7. Shut down the engine and allow the piping to cool.
8. Remove the 3/8" NPT coupling and piping.
9. Apply a graphite-base anti-seize compound to the cleanout pipe threads.
10. Reinstall the hex pipe cap, spark arrestor access plate, gasket and two screws.

⚠ WARNING ⚠

- ⚠ The exhaust system of this product gets extremely hot and remains hot after shutdown. High grass, weeds, brush, leaves, etc. must remain clear of the exhaust. Such materials may ignite and burn from the heat of the exhaust system.

⚠ WARNING ⚠

- ⚠ Be sure to reinstall the the hex pipe cap tightly to the spark arrestor cleanout pipe. Vibration could cause a loose cap to fall out, resulting in hot engine exhaust being drawn through the centrifugal cooling fan and out beneath the unit. This could result in damage to the generator or discharge of hot exhaust sparks beneath the unit.

Figure 3.3 – Spark Arrestor Muffler Maintenance

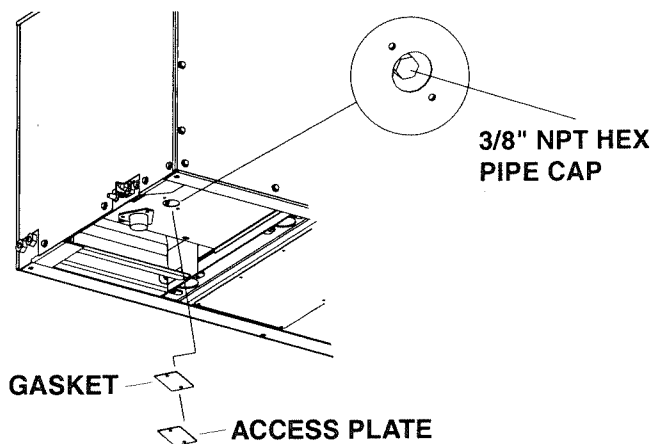

3.5 CLEANING THE GENERATOR

Keep your generator as clean and as dry as possible. Dirt and moisture that accumulate on internal generator windings have an adverse effect on insulation resistance.

Periodically, clean the generator's exterior surfaces. A soft brush may be used to loosen caked-on dirt. You can use a vacuum system or dry, low pressure air to remove any accumulations of dirt. The generator is housed inside an all-weather enclosure; clean the enclosure with a soft, damp cloth or sponge and water.

Once each year, have the generator cleaned and inspected by a Generac Authorized Service Dealer. Service technicians will use dry, low pressure air to clean internal windings. Parts inside the control console should be cleaned and inspected at this time as well.

Finally, have the insulation resistance of stator and rotor windings checked. If insulation resistances are excessively low, the generator may require drying.

⚠ CAUTION ⚠

- ⚠ Do NOT use a forceful spray of water to clean the generator. Water will enter the generator interior and cause problems, and may also contaminate the generator fuel system.

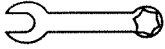
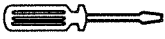

3.6 BATTERY MAINTENANCE

All lead-acid batteries will discharge when not in use. The generator battery should be inspected per the "Service Schedule," Section 3.13 (Page 16). The following procedure should be used for inspection:

- Inspect the battery posts and cables for tightness and corrosion. Tighten and clean as necessary.
- Check the battery fluid level of unsealed batteries and, if necessary, fill with Distilled Water Only. Do not use tap water in batteries.
- Have the state of charge and condition checked by a Generac authorized Service Dealer.

NOTE:

Servicing of the battery is to be performed or supervised by personnel knowledgeable of batteries and the required precautions. Keep unauthorized personnel away from batteries.

Damage will result if the battery connections are made in reverse.

—  **DANGER**  —

 Do not dispose of the battery in a fire. The battery is capable of exploding. Storage batteries give off explosive hydrogen gas. This gas can form an explosive mixture around the battery for several hours after charging. The slightest spark can ignite the gas and cause an explosion. Such an explosion can shatter the battery and cause blindness or other injury. Any area that houses a storage battery must be properly ventilated. Do not allow smoking, open flame, sparks, or any spark producing tools or equipment near the battery. Discharge static electricity from your body before touching the battery by first touching a grounded metal surface.

 A battery presents a risk of electrical shock and high short circuit current. The following precautions are to be observed when working on batteries:

- Remove watches, rings or other metal objects;
- Use tools with insulated handles;
- Wear rubber gloves and boots;
- Do not lay tools or metal parts on top of the battery;
- Disconnect any charging source prior to connecting or disconnecting battery terminals; and
- Do not use any jumper cables or booster battery to crank and start the generator engine. If any battery has discharged, remove it for recharging.

—  **WARNING**  —

 Do not open or mutilate the battery. Released electrolyte has been known to be harmful to the skin and eyes, and to be toxic.

 The electrolyte is a dilute sulfuric acid that is harmful to the skin and eyes. It is electrically conductive and corrosive. The following procedures are to be observed:

- Wear full eye protection and protective clothing;
- Where electrolyte contacts the skin, wash it off immediately with water;
- Where electrolyte contacts the eyes, flush thoroughly and immediately with water and seek medical attention.
- Spilled electrolyte is to be washed down with an acid neutralizing agent. A common practice is to use a solution of 1 pound (500 grams) bicarbonate of soda to 1 gallon (4 liters) of water. The bicarbonate of soda solution is to be added until the evidence of reaction (foaming) has ceased. The resulting liquid is to be flushed with water and the area dried.

3.7 COOLING SYSTEM

Air intake and outlet openings in the generator compartment must be open and unobstructed for continued proper operation. This includes such obstructions as high grass, weeds, brush, leaves and snow.

Without sufficient cooling and ventilating air flow, the engine/generator quickly overheats, which causes it to shut down.

3.8 ENGINE COOLANT

Check the coolant level in the coolant recovery tank at least once daily or prior to use. Add the recommended coolant mixture (see Section 1.5.4, Page 6) as necessary; the bottle should be kept half full. If desired, you may add a high quality rust inhibitor to the recommended 50-50 coolant mixture. If added consistently, the recommended mixture will protect the unit against freezing temperatures.

Periodically remove the radiator pressure cap to make sure the coolant recovery system is functioning properly. Coolant should be at the bottom of the radiator filler neck. If the coolant level is low, inspect the gasket in the radiator pressure cap. Replace the cap, if necessary. To have the pressure cap tested, contact a Generac Authorized Service Dealer. Inspect the cooling system and coolant recovery system for leaks.

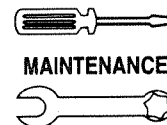

—▲ **DANGER** ▲—

▲ Do not remove the radiator pressure cap while the engine is hot or serious burns from boiling liquid or steam could result.

▲ Ethylene glycol base antifreeze is poisonous. Do not use your mouth to siphon coolant from the radiator, recovery bottle or any container. Wash your hands thoroughly after handling. Never store used antifreeze in an open container because animals are attracted to the smell and taste of antifreeze even though it is poisonous to them.

—▲ **CAUTION** ▲—

▲ Do not use any chromate base rust inhibitor with ethylene glycol base antifreeze, or chromium hydroxide ("green slime") will form and cause overheating. Engines that have been operated with a chromate base rust inhibitor must be chemically cleaned before adding ethylene glycol base antifreeze. Using any high silicate antifreeze boosters or additives also will cause overheating. We also recommend that you **DO NOT** use any soluble oil inhibitor for this equipment.

3.9 MAJOR SERVICE MANUAL

To obtain a service manual for your generator, contact Generac or your nearest Generac Authorized Service Dealer. Make sure to identify your MODEL NUMBER and SERIES.

3.10 DRIVE BELT

The engine drives the generator rotor by means of a pulley and drive belt arrangement. Drive belt tension was properly adjusted before the unit was shipped from the factory. If you suspect that drive belt tension is incorrect, contact a Generac Authorized Service Dealer.

3.11 EXERCISING THE GENERATOR

Generac recommends that you start and operate the generator at least once every seven days. Let the unit run for at least 30 minutes to "exercise" the engine. If you cannot exercise the generator every seven days, and it is to be out of service longer than 30 days, see Section 3.12.

3.12 OUT OF SERVICE PROCEDURE

◆ 3.12.1 REMOVAL FROM SERVICE

Prepare the generator for storage as follows:

1. Start the engine and let it run until it is thoroughly warmed up (at least five minutes), then shut off the engine.
2. While the engine is still warm from running, drain the oil completely. Refill the crankcase with the recommended oil (see Section 1.5.3, Page 6).
3. Attach a tag to the engine indicating the viscosity and classification of the oil in the crankcase.
4. Remove the battery and store it in a cool, dry room on a wooden board. Never store the battery on any concrete or earthen floor.
5. Clean and wipe the entire generator.

◆ 3.12.2 RETURN TO SERVICE

To return the unit to service after storage, proceed as follows:

1. Check the tag on the engine for oil viscosity and classification. Verify that the correct recommended oil is used in the engine (see Section 1.5.3, Page 6). If necessary, drain and refill with the proper oil.
2. Check the state of the battery. Fill all cells of unsealed batteries to the proper level with distilled water. **DO NOT USE TAP WATER IN THE BATTERY.** Recharge the battery to 100 percent state of charge, or, if defective, replace the battery.
3. Clean and wipe the entire generator.
4. Reconnect the battery. Observe battery polarity. Damage may occur if the battery is connected incorrectly.
5. Turn OFF all electrical loads. Add fuel if necessary and then start the engine.
6. Allow the unit to warm up thoroughly.
7. Apply electrical loads to at least 50 percent of the unit's rated wattage capacity.
8. When the engine is thoroughly warmed up, shut it down.
9. Your generator is now ready for service.

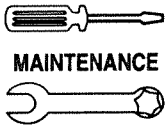

Section 3 – Maintenance
QUIETPACT™ 75D Recreational Vehicle Generator

3.13 SERVICE SCHEDULE

ATTENTION: It is recommended that all service work be performed by your nearest Generac Authorized Service Dealer.

SYSTEM/COMPONENT	PROCEDURE			FREQUENCY
	Inspect	Change	Clean	
X = Action R = Replace/Adjust as Needed * = To Be Completed by a Generac Authorized Service Dealer.				
FUEL				
Fuel level	X			AFTER 25-H BREAK-IN, D / BEFORE USE
Fuel lines and connections*	X			AFTER 25-H BREAK-IN, EVERY 250 H / 6 M
Fuel Filter*		X		EVERY 250 H / 6 M
LUBRICATION				
Oil level	X			EVERY 8 H / D
Oil		X		AFTER 25-H BREAK-IN, EVERY 250 H / 6 M
Oil filter		X		AFTER 25-H BREAK-IN, EVERY 250 H / 6 M
Oil line leakage*	X			EVERY 100 H
COOLING				
Engine cooling system*	X			AFTER 25-H BREAK-IN, EVERY 100 H / M
Coolant level	X			AFTER 25-H BREAK-IN, D / BEFORE USE
Coolant*		X		EVERY 500 H / Y
Enclosure louvers	X		X	EVERY 250 H / 6 M
EXHAUST				
Exhaust system	X			EVERY 100 H / M
Retorque Exhaust Manifold*	X			EVERY 750 H
Clean out Muffler/Spark Arrestor			X	EVERY 500 H
BATTERY				
Electrolyte fluid level	X			AFTER 25-H BREAK-IN, W
Charge and condition	X	R	X	W, EVERY 250 H / 6 M
FAN/ALTERNATOR BELTS				
Tension and condition*	X	R		EVERY 750 H
ENGINE				
Retorque cylinder head*	X			EVERY 750 H
Retorque intake manifold*	X			EVERY 750 H
Starter motor*	X			EVERY 750 H
Air filter	X	R		EVERY 500 H
Compression*	X			EVERY 750 H
Valve clearance*	X	R		EVERY 750 H
Governor*	X	R		EVERY 750 H
Safety devices*	X	R		EVERY 750 H
Injection system*	X	R		EVERY 750 H
GENERAL				
Overall condition	X		X	AFTER 25-H BREAK-IN, W
Exercise system				W
COMPLETE TUNE-UP*	X	X	X	Y

PART II – INSTALLATION INSTRUCTIONS

—▲ **DANGER** ▲—

**ONLY QUALIFIED ELECTRICIANS OR CONTRACTORS
SHOULD ATTEMPT INSTALLATION!!**



⚠ DANGER: For fire safety, installation of a generator into a recreational vehicle must comply strictly with article 551, NFPA 70; ANSI C1-1975; AND, ANSI A119.2-1975/NFPA 501C "Standard for Recreational Vehicles" (Part 3, "Installation of Electrical Systems"). In addition, installation must comply with the manufacturer's instructions and recommendations. **⚠**

NOTICE TO INSTALLER

These *Installation Instructions* have been published by Generac to aid in the installation of the products described in this manual. Generac assumes that installation personnel are familiar with the procedures for installing such products, or similar products that Generac manufactures. Generac also assumes that personnel have been trained in the recommended installation procedures for these products and that such training includes (a) use of common hand tools, (b) use of special Generac tools, and (c) use of any tools and/or equipment from other suppliers.

Generac cannot possibly know of and advise the recreational vehicle trade of all conceivable methods, procedures or techniques by which to perform an installation. Nor can Generac anticipate every possible hazard that might result from each installation method, procedure or technique. Generac has not undertaken any such wide evaluation. Therefore, people who use a method, procedure or technique that Generac does not specifically recommend must first completely satisfy themselves that their safety, the safety of the vehicle's occupants and the product's safety is not endangered by the method, procedure or technique selected.

Information, illustrations, specifications, etc., contained in these *Installation Instructions* are based on the latest information available at the time of publication. Every effort has been expended to be sure that such data is both accurate and current. However, the manufacturer reserves the right to change, alter or otherwise improve this product at any time without prior notice.

— ⚠ **DANGER** ⚠ —

⚠ Despite the safe design of this generator, operating this equipment imprudently, neglecting its maintenance or being careless can cause possible injury or death. Permit only responsible and capable persons to operate or maintain this equipment.

⚠ Parts of the generator are rotating and/or hot during operation. Exercise care near running generators.

⚠ Potentially lethal voltages are generated by these machines. Ensure all steps are taken to render the machine safe before attempting to work on the generator.

⚠ GENERAL HAZARDS ⚠

- For safety reasons, Generac recommends that the installation, initial start-up and maintenance of this equipment is carried out by a Generac Authorized Service Dealer.
- The engine exhaust fumes contain carbon monoxide, which can be DEADLY. This dangerous gas, if breathed in sufficient concentrations, can cause unconsciousness or even death. This exhaust system must be installed properly, in strict compliance with applicable codes and standards. Following installation, you must do nothing that might render the system unsafe or in noncompliance with such codes and standards. The generator compartment must be completely vapor sealed from the vehicle interior. There must be no possibility of exhaust fumes entering the vehicle interior. Never operate this equipment with a leaking or defective exhaust system.
- Keep hands, feet, clothing, etc., away from drive belts, fans, and other moving or hot parts. Never remove any drive belt or fan guard while the unit is operating.
- Adequate, unobstructed flow of cooling and ventilating air is critical to correct generator operation and is required to expel toxic fumes and fuel vapors from the generator compartment. Without sufficient cooling airflow, the engine/generator quickly overheats, which causes serious damage to the generator. Do not alter the installation or permit even partial blockage of ventilation provisions, as this can seriously affect safe operation of the generator.
- When working on this equipment, remain alert at all times. Never work on the equipment when you are physically or mentally fatigued.
- Before performing any maintenance on the generator, disconnect its battery cables to prevent accidental start up. Disconnect the cable from the battery post indicated by a NEGATIVE, NEG or (–) first. Reconnect that cable last.
- Never use the generator or any of its parts as a step. Stepping on the unit can stress and break parts, and may result in dangerous operating conditions from leaking exhaust gases, fuel leakage, oil leakage, etc.
- Never insert any tool or other object through openings in the generator interior, even if the unit is not running. You might seriously injure yourself or damage the equipment.



ELECTRICAL HAZARDS

- The generator covered by this manual produces dangerous electrical voltages and can cause fatal electrical shock. Avoid contact with bare wires, terminals, connections, etc., while the unit is running. Ensure all appropriate covers, guards and barriers are in place before operating the generator. If you must work around an operating unit, stand on an insulated, dry surface to reduce shock hazard.
- Do not handle any kind of electrical device while standing in water, while barefoot, or while hands or feet are wet. **DANGEROUS ELECTRICAL SHOCK MAY RESULT.**
- During installation onto the vehicle, properly ground (bond) the generator either by solid mounting to the vehicle frame or chassis, or by means of an approved bonding conductor. **DO NOT** connect the bonding conductor to any generator part that might be removed or disassembled during routine maintenance. If the grounding conductor must be replaced, use only a flexible conductor that is of No. 8 American Wire Gauge (AWG) copper wire minimum.
- If the vehicle electrical circuits can be powered by any other source of electricity (such as a “dockside” power receptacle), there must be no possibility of connecting the different power sources to the vehicle circuits at the same time. The dockside (utility) power source must be positively isolated from the vehicle circuits whenever the generator is operating. Failure to isolate the vehicle circuits from the dockside power supply when the generator is running may result in damage to the generator or serious injury or death to dockside (utility) power workers due to backfeed of electrical energy.
- In case of accident caused by electric shock, immediately shut down the source of electrical power. If this is not possible, attempt to free the victim from the live conductor. **AVOID DIRECT CONTACT WITH THE VICTIM.** Use a nonconducting implement, such as a rope or board, to free the victim from the live conductor. If the victim is unconscious, apply first aid and get immediate medical help.
- Never wear jewelry when working on this equipment. Jewelry can conduct electricity resulting in electric shock, or may get caught in moving components causing injury.

FIRE HAZARDS

- For fire safety, the generator must be installed and maintained properly. Installation always must comply with applicable codes, standards, laws and regulations. Adhere strictly to local, state and national electrical and building codes. Comply with regulations the Occupational Safety and Health Administration (OSHA) has established. Also, ensure that the generator is installed in accordance with the manufacturer's instructions and recommendations. Following proper installation, do nothing that might alter a safe installation and render the unit in noncompliance with the aforementioned codes, standards, laws and regulations.
- Keep a fire extinguisher in the vehicle at all times. Extinguishers rated “ABC” by the National Fire Protection Association are appropriate for use on the recreational vehicle generator electrical system. Keep the extinguisher properly charged and be familiar with its use. If you have any question pertaining to fire extinguishers, consult your local fire department.

EXPLOSION HAZARDS

- Do not smoke around the generator. Wipe up any fuel or oil spills immediately. Ensure that no combustible materials are left in the generator compartment, or on or near the generator, as **FIRE** or **EXPLOSION** may result. Keep the area surrounding the generator clean and free from debris.
- All fuel types are potentially **FLAMMABLE** and/or **EXPLOSIVE** and should be handled with care. Comply with all laws regulating the storage and handling of fuels.
- Fuel supply lines must be properly installed, purged and leak tested according to applicable fuel-gas codes before placing this equipment into service. There must be no possibility of fuel vapors entering the vehicle interior.
- You are required to install an approved, flexible, nonconductive fuel line between the generator fuel connection point and rigid fuel lines.

1.1 PURPOSE AND SCOPE OF THE MANUAL

These *Installation Instructions* have been prepared especially for the purpose of familiarizing installers and owners of the applicable equipment with the product's installation requirements. Give serious consideration to all information and instructions in the manual, both for safety and for continued reliable operation of the equipment.

Because of the different recreational vehicle models and the variations between the models, it would be extremely difficult, if not impractical, to provide detailed instructions for every possible installation. For that reason, instructions and illustrations in this manual are general in nature. Illustrations are not intended to serve as detailed installation blueprints.

The installation should comply strictly with all applicable codes, standards and regulations pertaining to the installation and use of this product. If any portion of this manual appears to be in conflict with such codes, standards or regulations, the applicable codes, standards or regulations must take precedence over the manual.

1.2 SAFETY

Before handling, installing, operating or servicing this equipment, carefully read the "Notice to Installer" and "Safety Rules" on Pages 18 and 19. Comply with all safety rules to prevent death, personal injury or damage to equipment and/or property. Stress safety to all installers, operators and service technicians who work on this equipment.

1.3 STANDARDS BOOKLETS

Installation, use and servicing of this equipment should comply strictly with published standards, as well as the manufacturer's recommendations. The following standards booklets (latest revision) are available from the sources indicated:

1. NFPA Standard 501C, "Standard for Recreational Vehicles," available from the National Fire Protection Association, Batterymarch Park, Quincy, MA 02269.
2. NFPA 70, "NFPA Handbook of the National Electric Code," available same as Item 1.
3. ANSI C1-1975 and ANSI 119.2-1975, available from the American National Standards Institute, 1430 Broadway, New York, NY 10018.
4. ANSI A119.2/NFPA 501C, available from the Recreational Vehicle Association, 1896 Preston White Drive, Reston, VA 22090.
5. California Administrative Code, Title 25, available from the State of California, Documents Section, P.O. Box 1015, North Highlands, CA 95660.

6. CSA Electrical Bulletin 946, available from the Canadian Standards Association, Housing and Construction Materials Section, 178 Rexdale Boulevard, Rexdale, Ontario, Canada, M9W 1R3.

1.4 EQUIPMENT DESCRIPTION

Instructions and information in this section pertain to Generac liquid-cooled generators designed specifically for installing in recreational vehicles. The QUIETPACT 75D operates 120/240-volt, single-phase, 60-Hertz, AC electrical loads that require up to 62.5 amps at 120 volts or 31.2 amps at 240 volts.

1.5 GENERATOR ENGINE OPERATING SPEED

The generator's two-pole revolving field (rotor) is driven by a three-cylinder, 1.0-liter diesel engine. The generator supplies 120/240 volts AC at 60 Hertz when the rotor is operating at 3,600 rpm. Engine speed is held nearly constant by a mechanical, fixed speed governor at 1,950 rpm.

1.6 GENERATOR AC CONNECTION SYSTEM

The generator is equipped with dual stator power windings as shown in Figure 1.1.

Figure 1.1 – Connections for 120/240 Dual Voltage

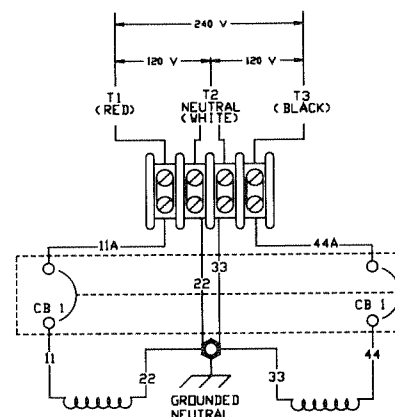

- The AC connection system uses a GROUNDED neutral. A separate green ground wire is connected to the recreational vehicle's junction box.
- For this QUIETPACT™ unit, each stator winding can support 120-volt, 60-Hertz, AC electrical output (3,600 rpm). When the two stator windings are connected in series, the unit can generate an output of 240 volts AC.

NOTE:

Do NOT connect loads in excess of circuit breaker ratings.

Figure 1.2 - Major Features and Dimensions

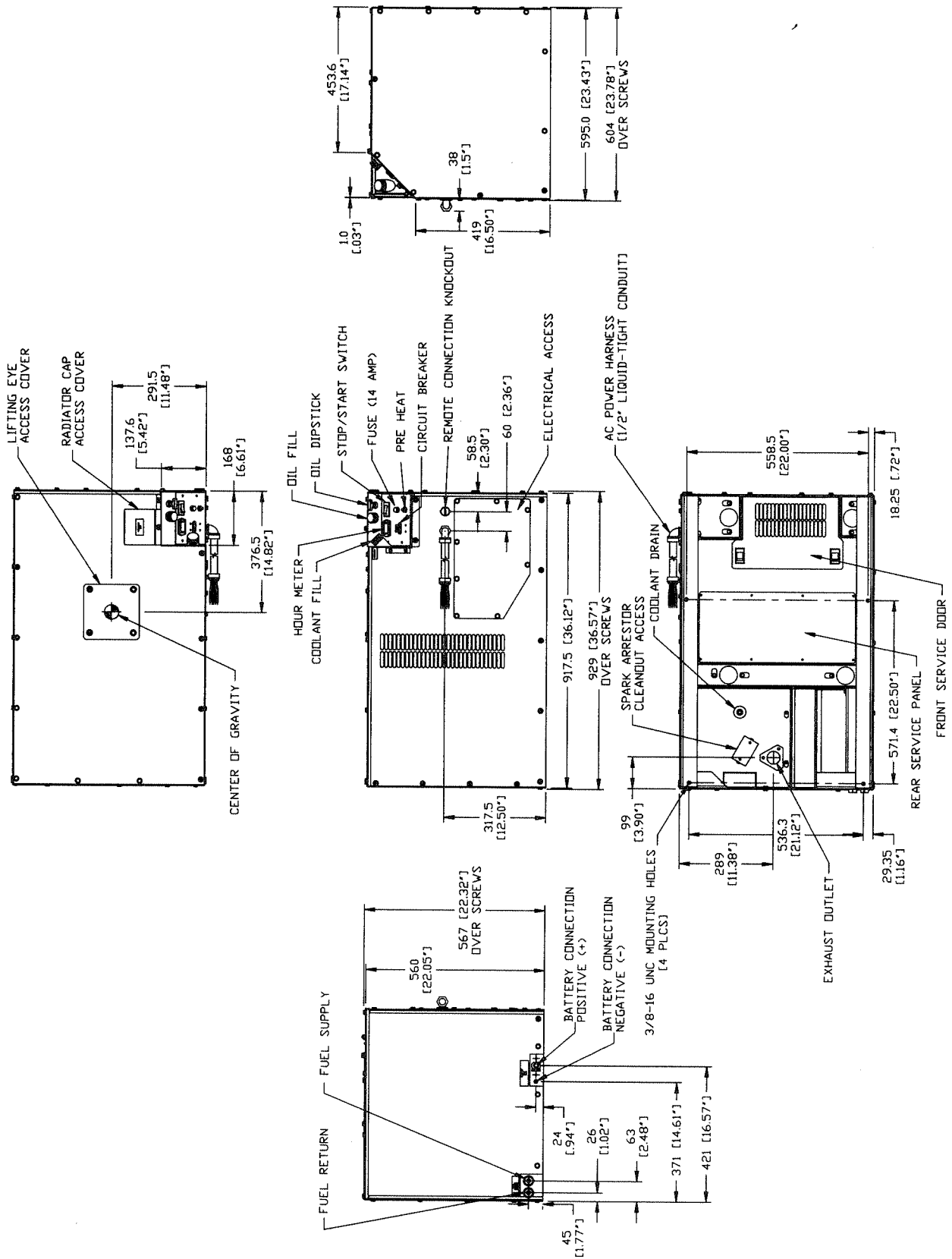



2.1 LOCATION AND SUPPORT

◆ 2.1.1 GENERATOR LOCATION

The most desirable location for the generator set is between the vehicle's main frame members.

Many recreational vehicles have been factory equipped with an area for the generator set. Some vehicles may even have a generator compartment provided by the vehicle manufacturer.

Plan the generator location based on the following:

- The generator set must be installed on a framework that is part of the recreational vehicle, as outlined in Section 2.1.2.
- The location must provide an access opening that is large enough to permit generator removal (unless the generator is to be removed from underneath the supporting framework).
- The location must provide easy access to frequently serviced components, such as filters, oil drains and other common maintenance parts.
- The location must provide sufficient room to allow minimum clearances for air circulation. If sound insulation is to be used on the compartment walls and ceiling, the minimum recommended applies to the space between the generator and such insulation.
- The location must provide adequate cooling and ventilating airflow for the generator without a great deal of work and expense.

◆ 2.1.2 GENERATOR SUPPORT

The generator must be securely attached to a metal framework that has been made part of the vehicle frame structure by bolting or welding. The metal framework on which the generator will rest and which will restrain the generator set should consist of at least two horizontal beams. These beams should consist of (a) 1-1/2-inch square, 11-gauge steel tubing OR (b) 1-1/2-inch, 11-gauge angle iron.

The generator can be installed so that it sits on top of the horizontal support tubing if the vehicle design permits. Another method is to suspend the generator below the horizontal support tubing by means of suitable, structurally sound metal framework. The following general rules apply:

- Vehicle construction **MUST** be capable of supporting the weight of the generator.

- Whether the generator is mounted above the horizontal support tubing or suspended below the tubing, the supporting frame used must be structurally sound.
- If the generator cannot be bolted directly to the supporting frame or support tubing, consider using additional tubing, angle brackets or other supports to give the supporting frame sufficient strength.

◆ 2.1.3 SUSPENDED MOUNTING

If you are going to suspend the generator below the horizontal support tubing, the suspension method you use with the vehicle frame members must (a) be able to support the weight of the generator AND (b) provide sufficient restraint for the generator. One typical suspended mounting system is shown in Figure 2.1. The location of a suspended mounting system must be carefully planned, keeping the following general rules in mind:

- Protect the generator against road splash and debris. Baffles or splash guards may be required to protect certain areas of the generator. To make sure the generator is adequately protected, road test the installation through mud, water and slush.

Figure 2.1 – Typical Suspended Mounting System

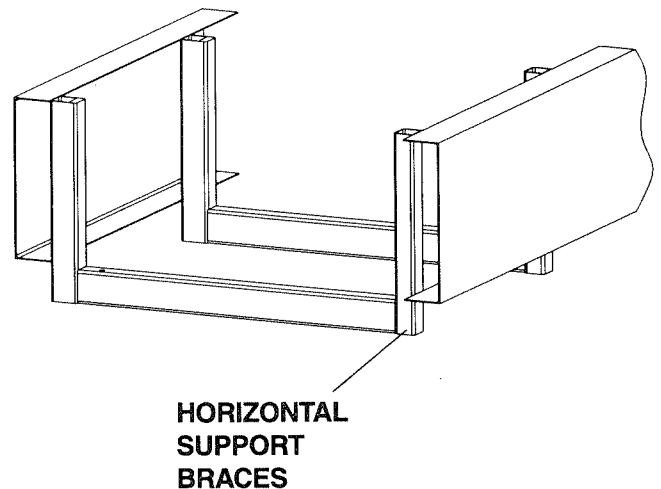

- The installer must make certain that the selected location will permit adequate cooling and ventilating airflow to be supplied.



◆ 2.1.4 GENERATOR RESTRAINT

Use four 3/8"-16 hardened steel bolts (Grade 5) to fasten the generator to the supporting frame or the support tubing. These bolts must pass through (a) the generator mounting base, (b) the compartment floor (if a compartment is used) and (c) the supporting framework (Figure 2.2). All bolts must be long enough so that when tight, are engaged at least 3/8" of an inch [9.5 millimeters]. Refer to Section 2.2 for the location of the generator mounting holes.

Figure 2.2 – Typical Generator Restraint

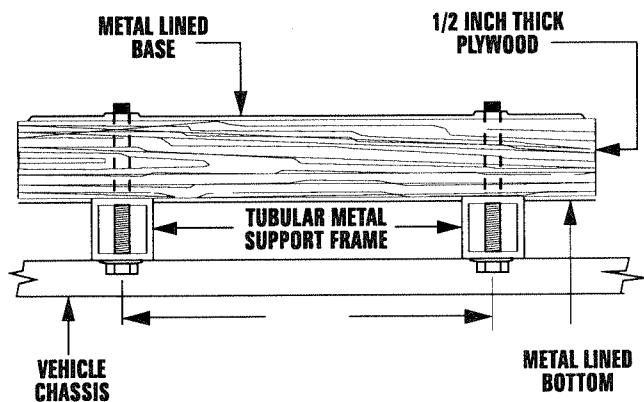

2.2 GENERATOR COMPARTMENTS

Whether the generator set is being installed inside a compartment specifically manufactured to house a generator or inside a compartment that the installer constructs, the compartment **MUST** meet certain specifications as outlined in the following sections:

◆ 2.2.1 COMPARTMENT CONSTRUCTION

- The generator compartment should be either constructed of, or lined with, 26-gauge galvanized steel.

NOTE:

Aluminum is NOT an acceptable alternative to galvanized steel due to aluminum's low melting point.

- If the compartment is lined with galvanized steel, it may be constructed of any material. Generac recommends that the compartment be constructed of 1/2-inch thick plywood (not strandboard), with the floor made of a double thickness of 1/2-inch plywood with the grain of the wood at cross section for added strength (Figure 2.3).

Figure 2.3 – Typical Compartment Construction

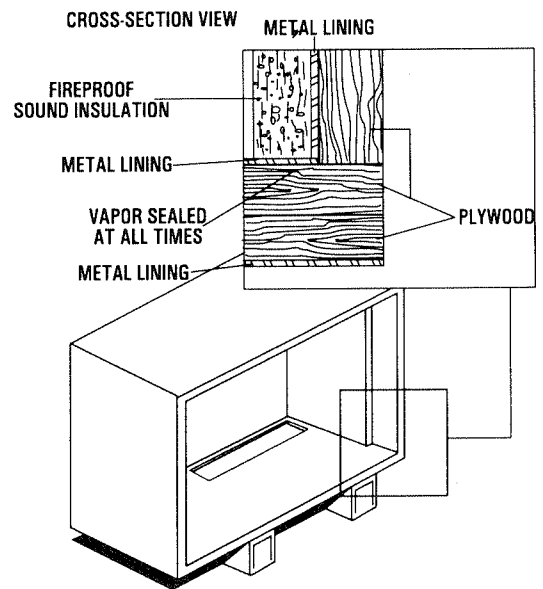

- If constructing a compartment, line the exterior (underside) of the compartment floor with 26-gauge galvanized steel.
- All seams, splices and joints of the compartment walls (unless vapor tight by design) should be caulked to prevent poisonous, flammable or explosive vapors from entering the vehicle interior.

NOTE:

Caulking must be done so that the caulking material will stay in place permanently. Pressing such materials as putty tape onto joints and seams is NOT acceptable. A high quality silicone rubber base sealant is recommended.

- Holes and openings made in the compartment walls to allow for the passage of electrical conduit, conductors, hoses, cables, etc., into the vehicle living area must be sealed vapor tight with silicone rubber base sealant.
- If flexible metal conduit is used, it must be sealed internally at the end where it terminates inside the compartment's electrical junction box.

NOTE:

Flexible metal conduit, due to its unique construction, is NOT vapor tight along its entire length.

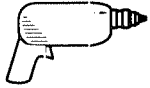

- Seams and joints of the galvanized steel (whether used as a liner or for the compartment itself) must be lapped and mechanically secured. Such seams may be manufactured, welded, bolted, riveted or screwed. Manufactured lock seams are shown in Figure 2.4. Installer constructed compartments typically utilize a standard lap joint.

Figure 2.4 – Types of Lock Seams

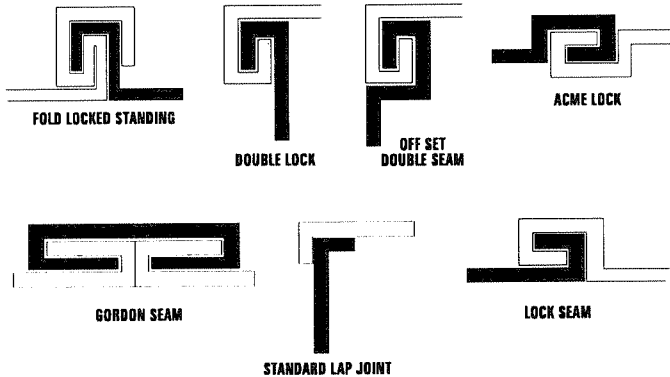

- After the compartment has been metal lined and vapor sealed, line the compartment interior walls and ceiling with an approved, nonflammable sound insulating material. See Section 2.2.2.



- ⚠ Do not install any flammable material directly above or around the compartment. Heat, transferred through the compartment structure, may be sufficient to ignite, char or discolor seat cushions, fiberboard and other flammable materials. You may need to use approved nonflammable insulating materials in high temperature areas.

◆ 2.2.2 SOUND INSULATING MATERIALS

Once installers have determined that a compartment is properly constructed and metal lined, they can add acoustical material. This may include additional sealant or insulating material, to reflect noise away from the vehicle interior.

Sound insulating materials should be of a nonflammable type. One excellent insulating material is a 1-inch (25 mm) thick fiberglass having a 2-pound density. When fiberglass is used, its coated side should face toward the compartment interior.



- ⚠ Do not install sound insulation or any absorbent material on the compartment floor interior. Such materials will become soaked with combustible or explosive vapors and liquids and will become a fire hazard.

Using a combination of sound insulating materials can often reduce noise more effectively than a single material. For example, a sheet of lead or viscoelastic material, along with a layer of other acoustical material, is more effective than when a single material is used.

◆ 2.2.3 ACOUSTICS

For additional noise abatement, the installer may wish to consider the following:

- Using special sound insulating materials.
- Construction of a special noise abatement compartment.

NOTE:

Any method used to reduce noise must not adversely affect the flow of cooling and ventilating air into or out of the compartment.

In addition to the effective use of sound insulating materials, construction of a special noise abatement compartment might be considered to reduce noise levels. Such a compartment might be constructed as follows (Figure 2.5, Page 25):

- Use 5/8-inch thick or 3/4-inch thick plywood in the compartment.
- Construct the compartment floor of a double thickness of 5/8-inch or 3/4-inch plywood.
- Line the compartment interior walls and floor, as well as the underside of the floor, with 26-gauge galvanized steel.
- Vapor seal all compartment seams and joints.
- Over the galvanized steel lining, install a combination of acoustical materials as mentioned in Section 2.2.2.



- ⚠ To prevent fire or explosion, do not install any insulation or other absorbent materials on the interior or underside of the compartment floor.

- Seal all compartment door edges to prevent noise leakage around the door perimeter.
- Line the compartment door interior (except for air openings) with suitable, fireproof sound insulation (such as 1-inch (25 mm) thick fiberglass with a 2-pound density).

Figure 2.5 – Typical Noise Abatement

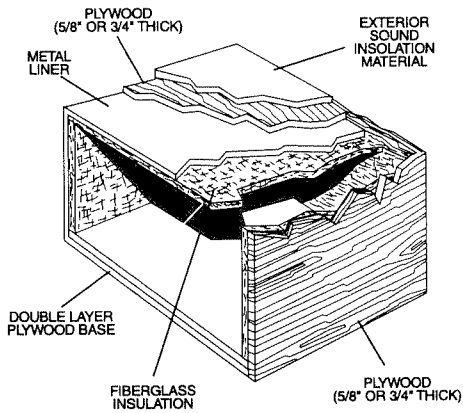

◆ 2.2.4 COMPARTMENT FLOOR CUTOUTS

You must provide openings in the generator compartment for the following items (Figure 2.6):

- Engine exhaust and cooling air outlets
- Generator cooling air inlet
- Four holes for passage of generator mounting bolts. See Section 2.1.4 (Page 23).

⚠ DANGER ⚠

⚠ Fuel lines and exhaust piping must not penetrate into the vehicle living area.

Figure 2.6 – Compartment Floor Cutout

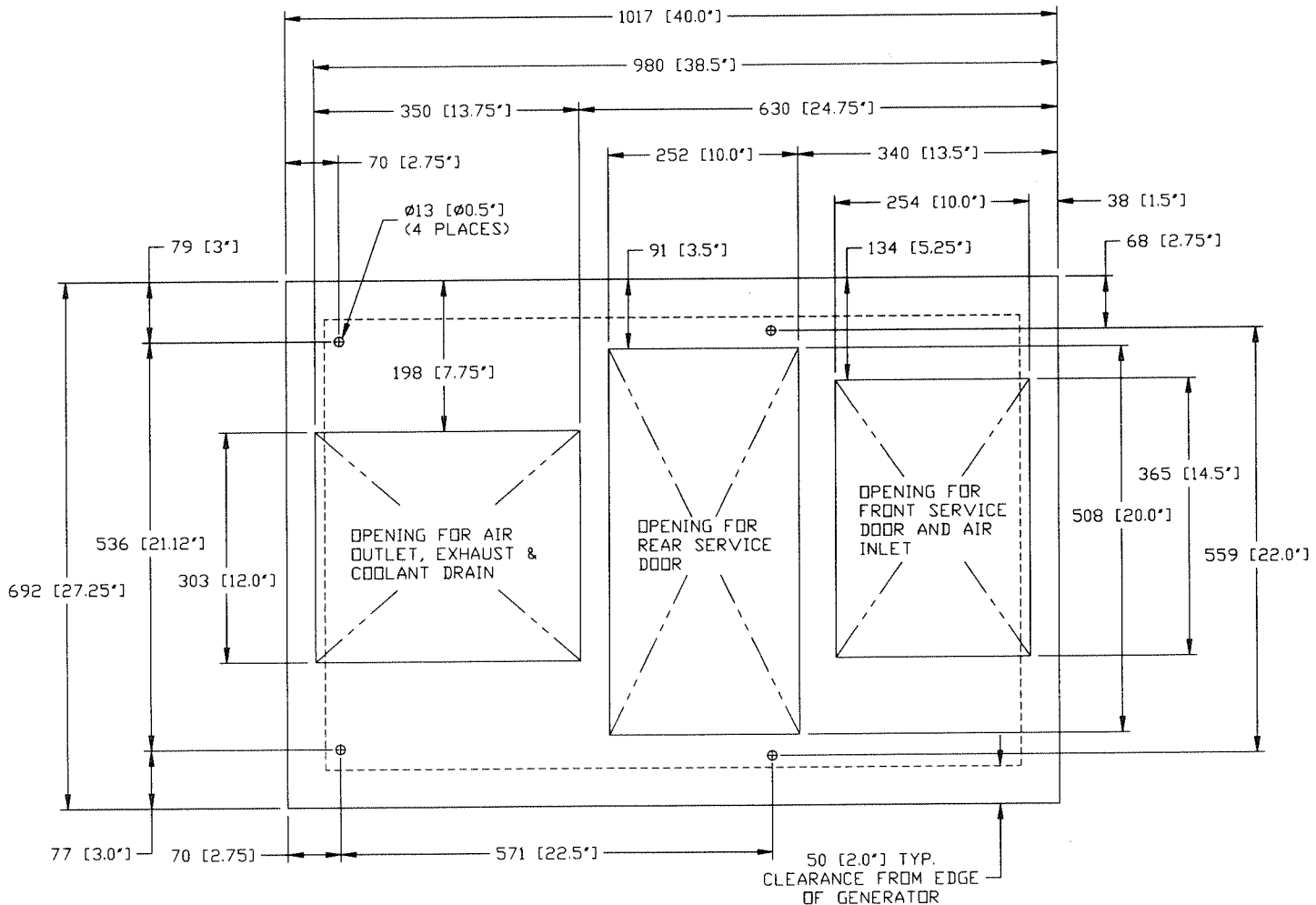

NOTE: FOR A FULL SIZE TEMPLATE, CONTACT GENERAC SERVICE DEPARTMENT AT: 1-262-544-4811

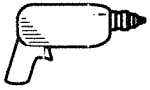

2.3 COOLING AND VENTILATING AIR

It is absolutely essential that an adequate flow of air for cooling, ventilating and engine combustion be supplied to the generator set. Without sufficient airflow, the engine/generator quickly overheats. Such overheating can cause serious operating difficulties and also may cause fire and personal injury. The installer must make sure that sufficient air is available to the generator for cooling, ventilating and combustion. The installer also must provide for a path for exhausting the cooling air to the exterior of a compartment, if so equipped.



Never use discharged cooling air for heating or permit such air to enter the vehicle interior. This air contains deadly carbon monoxide gas and other poisonous, flammable or explosive gases.

2.3.1 GENERATOR AIRFLOW

This unit uses a centrifugal blower to cool the generator's internal components. Blower fan air is then expelled from a blower air outlet duct. The engine cooling fan draws air in through air inlet openings, moves that air around the engine/generator and across the radiator, then discharges that air out the bottom (see Figure 2.7).

Figure 2.7 – Airflow Through Engine/Generator

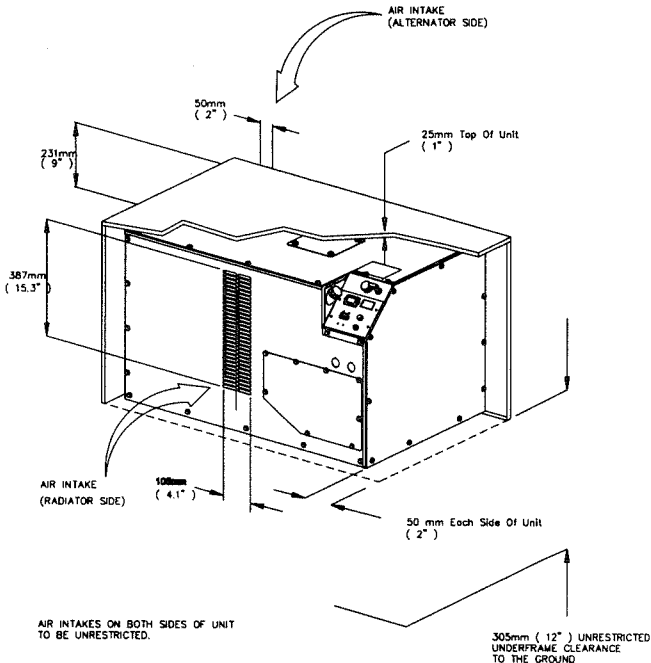

2.3.2 COOLING AIR INLET OPENINGS

The minimum size of the air inlet opening, whether the generator is housed in a conventional compartment or not, is **at least 150 square inches (975 cm²)** (see Figure 2.8). This rule applies whether inlet air is brought in through an opening in the compartment door, an opening in the vehicle skirt, through ductwork, or by any other means.

NOTE:

Screening, louvers or expanded metal that cover air openings restrict airflow. You must compensate for this by making the actual air opening proportionately larger. See Section 2.3.3 (Page 27).

Figure 2.8 – Air Inlet in Compartment Door

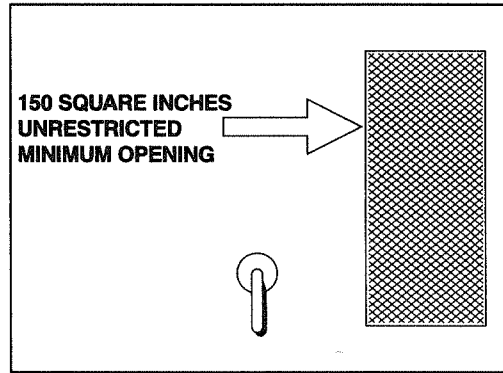

When the unit is installed on a suspended mounting system, one of several different methods of supplying airflow may be used as follows:

- Provide a door in the vehicle skirt having an air inlet opening (Figure 2.9).

Figure 2.9 – Suspended Mount: Inlet Door

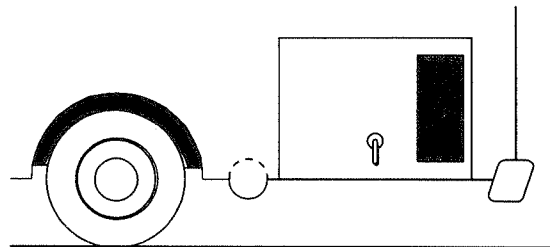

- Using ductwork (Figure 2.10, Page 27). The installer must be sure air is available to the top of the generator since air inlets are located at the top.
- By providing an opening in the vehicle skirt and space behind the generator for cooling airflow (Figure 2.11 Page 27). Recommended clearance behind the back of the generator is at least 2 inches (50 mm).



Figure 2.10 – Air Inlet Using Ductwork

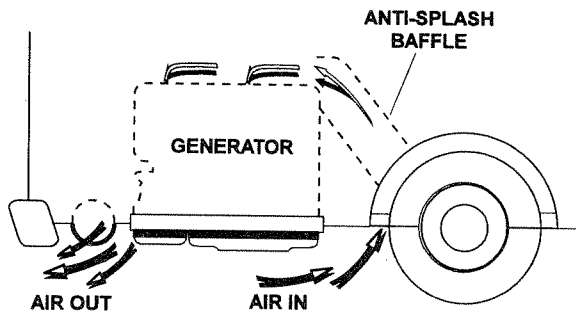
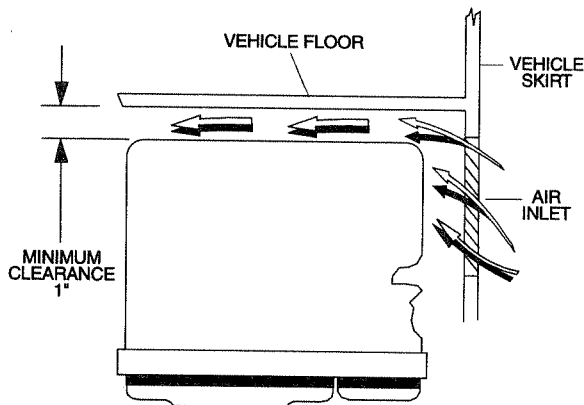

Figure 2.11 – Air Inlet in Vehicle Skirt



◆ 2.3.3 COMPENSATING FOR RESTRICTIONS

Such materials as screening, louvers or expanded metal can restrict the free flow of air. Compensate for this restriction by making the actual air opening proportionately larger.

Some materials may offer only a 60 percent “free air inlet area.” Other more efficient materials may provide up to a 90 percent free air inlet area. The percentage of free air inlet opening is usually available from the material supplier or manufacturer.

To determine the actual air inlet opening size required, divide 150 square inches (975 cm²) by the percentage of free air inlet area for the material you will use.

For example: If you plan to use screening with an 80 percent free air inlet area, divide 150 (975) by 0.8, which results in 187.5 square inches (1,218.75 cm²). Minimum actual size of air inlet opening in this case is 187.5 square inches (1,218.75 cm²).

◆ 2.3.4 TESTING THE INSTALLATION

Generac recommends testing the installation to be sure adequate cooling airflow is available to the unit before placing the unit into service. If the unit shows signs of overheating, you will need to enlarge the air openings. Never place a unit into service until absolutely certain that cooling and ventilation is adequate.

NOTE:

You must test the installation, especially if you bring in air from below the generator set.

2.4 DIESEL FUEL SYSTEM

The installation of a diesel fuel system (Figure 2.12) for a recreational vehicle generator set must comply with applicable codes, standards and regulations. The entire fuel system must be completely free of leaks. There must be no possibility of fuel vapors entering the vehicle interior.

Figure 2.12 – Generator Fuel System

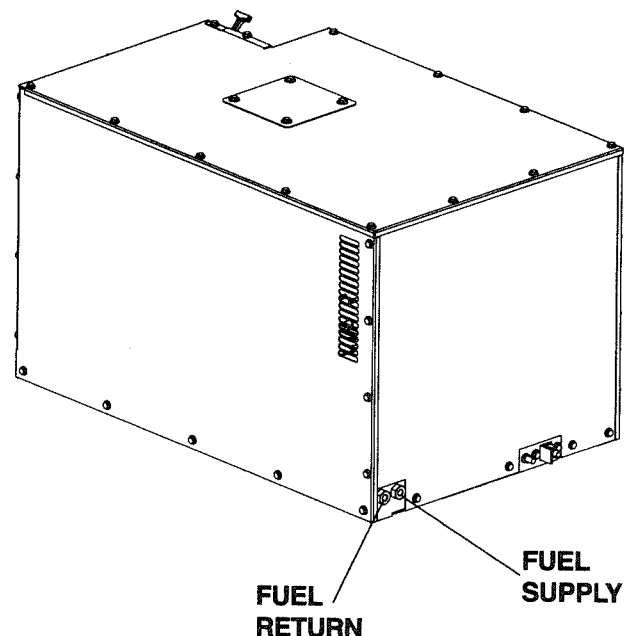

▲ DANGER ▲

▲ All fuel types are potentially FLAMMABLE and/or EXPLOSIVE and should be handled with care. Comply with all laws regulating the storage and handling of fuels. Properly install and maintain the fuel system and keep it entirely free of leaks. Fuel vapors must not enter the vehicle interior.



Because diesel fuels are less volatile than gasoline or gaseous fuels, they are considered safer from the standpoint of storage and handling. As a result, installers may tend to be careless in their installation practices, which can result in poor engine performance. For example, a poorly tightened fuel line may not show any signs of leakage; however, air can be drawn into the loose connection and cause problems. Air that is trapped in the diesel fuel system results in hard starting and rough engine operation.

Dirt that enters the fuel system also may cause problems. Lines and piping must be properly installed and tightened to prevent dirt from entering. Diesel fuel must be kept clean.

Factory installed generator fuel system components include (a) fuel filter, (b) 12-volt DC electric pump, (c) injection pump, and (d) interconnecting lines and fittings. Connect a fuel supply line to the fuel inlet and the return line back to the tank. Use a flexible length of approved fuel hose between the fuel filter inlet connection and rigid fuel lines.

◆ 2.4.1 FUEL TANK

Either the generator must share the vehicle engine's fuel tank, or you must install a separate fuel tank for the generator set. All fuel tanks installed on the vehicle must be constructed, installed and restrained so they comply with applicable codes, standards and regulations.

If the generator is to share the vehicle engine's tank, separate fuel pickup tubes are required for the engine and the generator. Generac recommends that you make the fuel pickup tube 2 to 3 inches (51 to 76 mm) shorter than the vehicle engine's pickup tube. This prevents the generator from depleting the entire fuel supply during prolonged generator operating periods.

▲ CAUTION ▲

▲ Do NOT tee the generator fuel supply line into the vehicle engine fuel supply line. If this is done, the generator will be starved of fuel when both engines are operating at the same time. Also, while the vehicle engine is not running, generator operation may drain the vehicle engine supply line, making it difficult to start the vehicle engine.

◆ 2.4.2 GENERATOR FUEL SUPPLY LINES

▶ 2.4.2.1 Rigid Fuel Lines

Those lines used to supply fuel from a tank to the generator must comply with applicable codes, standards and regulations. The following general rules apply to rigid fuel lines:

- Rigid lines should be of annealed, seamless, drawn aluminum or steel.
- Lines and fittings must comply with SAE J512F, "Standard Automotive Fittings," or with ANSI B126.26 (latest edition).
- Route the fuel line so that at least 2 inches (51 mm) of clearance is maintained between the line and any exhaust system parts.
- Do not attach electrical wiring to fuel lines. Route the wiring so it cannot come into contact with any fuel line.
- Route fuel lines so if they leak, fuel does not drip onto any electrical or exhaust system parts.
- Use nonferrous metal straps without sharp edges to secure fuel lines.
- Fuel system components must be accessible, but protected from abrasion, chafing, road damage and kinking.

▶ 2.4.2.2 Flexible Fuel Line

Use an approved flexible length of fuel hose between the generator fuel inlet connection and rigid fuel lines. This prevents breaking of the line caused by vibration, shifting, settling or movement. The following rules apply:

- The flexible hose must comply with SAE J30B, "Standard for Fuel and Oil Hose." It must be approved for use with diesel fuel.
- The hose should be at least 6 inches (152 mm) longer than is needed to prevent the hose from rupturing if the generator shifts or settles.

◆ 2.4.3 GENERATOR FUEL RETURN LINES

The same general rules that apply to fuel supply lines also apply to fuel return lines.

NOTE:

Locate the diesel fuel return line at least 12 inches from the tank fuel pickup tubes to prevent air bubbles from entering the fuel supply lines.

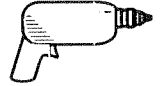

2.5 EXHAUST SYSTEM

The generator exhaust system must be safely and properly installed. Only approved mufflers and other exhaust system parts must be used. A properly installed exhaust system must be vapor tight, quiet and completely safe.

▲ DANGER ▲

- ▲ The generator engine gives off **DEADLY** carbon monoxide gas through its exhaust system. This dangerous gas, if breathed in sufficient concentrations, can cause unconsciousness or even death. Never operate the generator set with the vehicle inside any garage or other enclosed area. **DO NOT OPERATE THE GENERATOR IF THE EXHAUST SYSTEM IS LEAKING OR HAS BEEN DAMAGED. SYMPTOMS OF CARBON MONOXIDE POISONING ARE (a) inability to think coherently; (b) vomiting; (c) twitching muscles; (d) throbbing temples; (e) dizziness; (f) headaches; (g) weakness; and (h) sleepiness. IF YOU FEEL ANY OF THESE SYMPTOMS, MOVE INTO FRESH AIR IMMEDIATELY. IF SYMPTOMS PERSIST, GET MEDICAL HELP.** Do not operate the generator until its exhaust system has been inspected and properly repaired.

▲ CAUTION ▲

- ▲ Never tee the generator engine exhaust pipe into the vehicle engine exhaust piping. This causes excessive back pressure on the generator engine. Also, water from one engine can damage the other engine.

◆ 2.5.1 MUFFLERS AND SPARK ARRESTORS

This muffler meets code and standard requirements of the U.S. Forest Service. Use only mufflers and parts approved by Generac. Any person(s) installing an unapproved muffler, or an unapproved exhaust system part, or modifying an exhaust system in any way that might cause a hazard, is liable for any damage, injury or warranty expense that might be caused by such unapproved installation or modification.

Failure to provide and maintain a spark arrestor may be in violation of the law. If this generator is used on any forest covered, brush covered or grass covered unimproved land, you must provide a spark arrestor. The vehicle owner or operator must maintain this device in good condition. In the state of California, the preceding is required by law (Section 4442 of the California Public Resources Code). Other states may have similar laws. Federal laws apply on federal lands.

◆ 2.5.2 EXHAUST SYSTEM SAFETY

- Maintain a clearance of at least 3 inches (76 mm) between exhaust system parts and any combustible material (such as wood, felt, cotton, organic fibers or other like material). If you cannot maintain the 3-inch (76 mm) clearance, locate, insulate or shield the exhaust part(s) so that the temperature of any combustible material is not raised more than 117° F (65° C) above the ambient air temperature.
- Terminate the exhaust tailpipe at least 3 feet (91 cm) from the vehicle's fuel filler cap and at least 2 inches (51 mm) past the outer edge of the vehicle. Do not terminate the exhaust system under the vehicle.
- Terminate the exhaust tailpipe such that exhaust gases will not be drawn back into the generator compartment and recirculated.
- Fuel and oil must NOT be able to drip onto any exhaust system part.
- The hole in the generator compartment floor through which the exhaust pipe passes must be larger than the exhaust pipe. Hole size should permit installation of a ventilated metal thimble that is at least 2 inches larger in diameter than the exhaust pipe (Figure 2.13)

Figure 2.13 – Typical Exhaust System

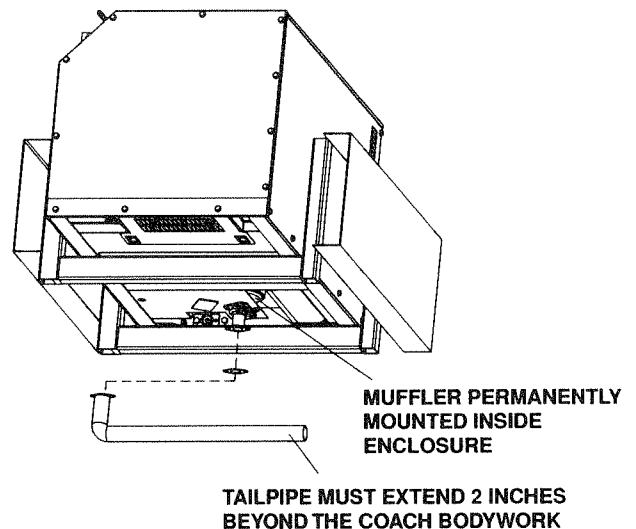

- If there is any possibility of the tailpipe or muffler being damaged, protect these damage-prone areas by means of a protective device (such as a skid bar).
- Install the generator exhaust system according to safe automotive practices.
- Use enough exhaust system hangers to prevent any part of the system from being dislocated.

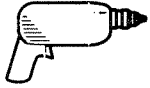

- Use exhaust system parts recommended by Generac. Using unapproved exhaust mufflers and exhaust system parts is the responsibility of the person(s) installing such unauthorized parts.
- Do not terminate the exhaust system under any opening, window or vent that can be opened or is not permanently sealed from the vehicle interior.
- Exhaust piping must be large enough to prevent excessive back pressure on the generator engine.
- Never tee the generator engine exhaust pipe into the vehicle engine exhaust piping. This causes excessive back pressure on the generator engine. Also, water from one engine can damage the other engine.
- Plan exhaust system installation carefully. Comply with all applicable codes, standards and regulations.

2.6 ELECTRICAL CONNECTIONS

Be sure to read Section 1.6 on Page 20.

The following general rules apply to electrical connections in a recreational vehicle:

- Qualified electricians who are familiar with applicable codes, standards and regulations should install electrical wiring.
- The wiring should comply with codes, standards and regulations. The National Electrical Code (NFPA 70), and state and local codes apply.
- Switches and circuit breakers should be of a type approved for use in recreational vehicles and must be mounted and installed to prevent damage from road shock.
- Wiring must be of adequate size, have approved insulative qualities and be properly supported.
- Conduit and wire openings into the generator compartment (if used) must be vapor-sealed to prevent entry of flammable, explosive or poisonous gases into the vehicle.

◆ 2.6.1 ELECTRICAL JUNCTION BOX

Install an approved, square electrical junction box with a blank cover on the interior or exterior wall of the area you plan to install the generator (NOT on the generator). Route the generator's AC output leads into this junction box through approved flexible conduit. This is the point of first termination for generator AC output leads.

◆ 2.6.2 WIRING

- Wiring should be of stranded copper to reduce the chance that vibration may cause breakage.
- Wire gauge size should be large enough to handle at least 115 percent of the installed generator's rated maximum current.

- If neutral conductors are used, they must be the same size as other leg wires.
- Route power supply conductors from generator AC output leads T1 (red), T2 (white), T3 (black) and the green ground wire through approved flexible conduit to the electrical junction box on the compartment wall.
If flexible metal conduit is used between the generator and the compartment junction box, the conduit end that terminates the compartment junction box must be vapor-sealed. Flexible metal conduit is NOT vapor tight along its entire length.
- From the junction box, route power supply wires through approved conduit to either (a) double-pole, double-throw transfer switch, or (b) approved isolation receptacle. Connecting to a transfer switch or isolation receptacle must prevent vehicle electrical circuits from being connected to two different power supplies at the same time (such as generator and dockside power).
- Conductors must be rated 221° F (105° C) or must be of a larger conductor size.

◆ 2.6.3 GENERATOR AC CONNECTIONS

Generator AC output leads T1 (red), T2 (white) and T3 (black) come out of the generator as shown in Figure 2.14. Leads T1 (red) and T3 (black) are "hot," while T2 (white) is the grounded neutral lead. There is also a green lead that connects to ground in the junction box of the recreational vehicle.

Figure 2.14 – Generator AC Output Leads

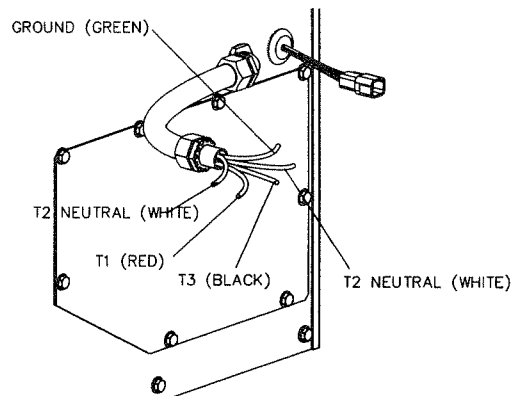

QUIETPACT™ generators use a four-position terminal block to connect between stator power leads and vehicle load leads. This terminal block is accessible by removing the access panel shown in Figure 2.14. Units are shipped from the factory connected for dual voltage (120/240 volts AC) output (See Figure 2.15). The stator power windings are connected in series. Lead 11/11A connects to T1 (Red), lead 44/44A connects to T3 (Black), while leads 22 and 33 are grounded and connect to T2 NEUTRAL (White). A "tie bar" connects the two switch handles on line breaker CB1.



► 2.6.3.1 Generator Conversion to 120 Volts Only – Dual Circuits

NOTE:

Conversion of a QUIETPACT™ generator from "120/240 volt dual voltage" to "120 volts only - dual circuits" (or vice-versa) requires re-routing wires within the unit enclosure. It is recommended that this conversion be performed by a Generac Authorized Service Dealer.

Figure 2.16 shows the stator power winding connections for 120 volts only - dual circuits. Two stator power windings are used, with each winding capable of supplying half of the unit's rated wattage/ampere capacity. The circuit from each winding is protected against overload by a line breaker (CB1 and CB1A). Line breakers CB1 and CB1A have a trip rating of 35 amps.

To convert from "120/240 volt dual voltage" to "120 volts only - dual circuits", disconnect battery power from the generator and reverse stator lead wires 33 and 44 as follows:

NOTE:

It is necessary to feed stator lead wires 33 and 44 through grommets on the electrical enclosure and engine controls box in order to perform the re-routing outlined below. The front and top unit enclosure panels as well as the user controls panel must be removed to perform this. After re-routing, wires should be properly tied down to prevent chafing or contact with moving internal components

1. Re-route stator lead wire 44 from the line side terminal of CB1A to the ground stud location previously occupied by stator lead wire 33.
2. Move smaller gauge (#18 AWG) wire labeled #44, from the top of CB1A to the top of CB1. Renumber this wire #11.
3. Re-route stator lead wire 33 from the ground stud adjacent to the four-position terminal block to the line side terminal on CB1 (renamed as CB1A in Figure 2.16).
4. Re-number ground wire "33" located between the four-position terminal block and ground as wire "44".
5. Re-number wire "44A" as "33A".
6. Connect a 12 AWG jumper wire between line breakers CB1 and CB1A as shown in Figure 2.16.
7. Remove the "tie bar" between the two line breaker switch handles.

When connecting vehicle load leads, the following rules apply:

- Connect 120-volt, single-phase, 60-Hertz, AC electrical loads requiring up to the trip rating of circuit breaker CB1 across AC output leads T1 (red) and T2 (white).

- Connect 120-volt, single-phase, 60-Hertz, AC electrical loads requiring up to the trip rating of circuit breaker CB1A across AC output leads T3 (black) and T2 (white).
- Try to keep the load balanced between the two circuit breakers and stator windings.
- The neutral line (T2, white) on all units is a grounded neutral.



Do NOT connect electrical loads in excess of any circuit breaker rating or you will develop problems with circuit breaker tripping, which causes a loss of AC output. Also, do NOT exceed the generator's rated wattage capacity. Add the watts or amps of all lighting, appliance, tool and motor loads the generator will operate at one time. This total should be less than the unit's rated wattage/ampere capacity.

Figure 2.15 – Connections for 120/240 Dual Voltage

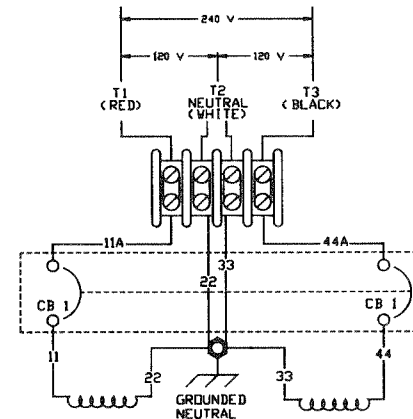
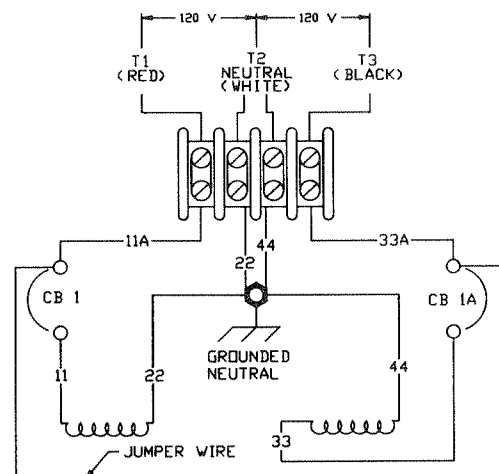
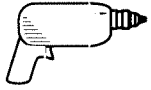

Figure 2.16 – Connections for 120 Volts Only – Dual Circuits





◆ 2.6.4 CONDUIT

Route the connections between the generator and the junction box through approved, flexible conduit. The following general rules apply:

- All wiring, conduit and interconnections must be installed in compliance with applicable codes, standards and regulations.
- Cut wiring to the required length and allow extra wire for junction box connections.
- Carefully prepare conduit ends to prevent sharp edges from cutting through wiring insulation.
- Route conduit so it does not interfere with generator movement.
- If you use metallic conduit, vapor seal the end of the conduit where it enters the junction box. Do this because flexible metallic conduit is not vapor-proof along its entire length.
- All openings in the generator compartment for the passage of wiring and conduit must be sealed and made vapor tight.

NOTE:

Use a high quality silicone rubber base sealant or other approved methods (such as explosion proof fittings) to seal such openings.

◆ 2.6.5 POWER SUPPLY CORD

The power supply cord must comply with all applicable codes, standards and regulations. It must be large enough to handle the full amperage to which it will be subjected.

◆ 2.6.6 GROUND FAULT CIRCUIT INTERRUPTERS

The National Electrical Code (NFPA 70, 551-7) requires that you install ground fault circuit interrupters (GFCIs) on all external and some internal electrical receptacles. Contact your manufacturer or dealer for recommendations.

◆ 2.6.7 ISOLATING DIFFERENT POWER SOURCES

Connections from the junction box must terminate in a double-pole, double-throw transfer switch (Figure 2.17). An alternate method for isolating different power sources is by using an isolating receptacle (Figure 2.18). Whichever method you use, you must be certain that both power sources are NOT connected at the same time.



⚠ If the vehicle electrical circuits can be powered by any other source of electricity (such as a “dock-side” power receptacle), there must be no possibility of connecting the different power sources to the vehicle circuits at the same time. The dockside (utility) power source must be positively isolated from the vehicle circuits whenever the generator is operating. Failure to isolate the vehicle circuits from the dockside power supply when the generator is running may result in damage to the generator or serious injury or death to dockside (utility) power workers due to backfeed of electrical energy. Installation and connection of the generator must comply with ANSI A119.2/NFPA 501C and ANSI/RVIA EGS-1 (latest editions).

Figure 2.17 – Transfer Switch Isolation Method

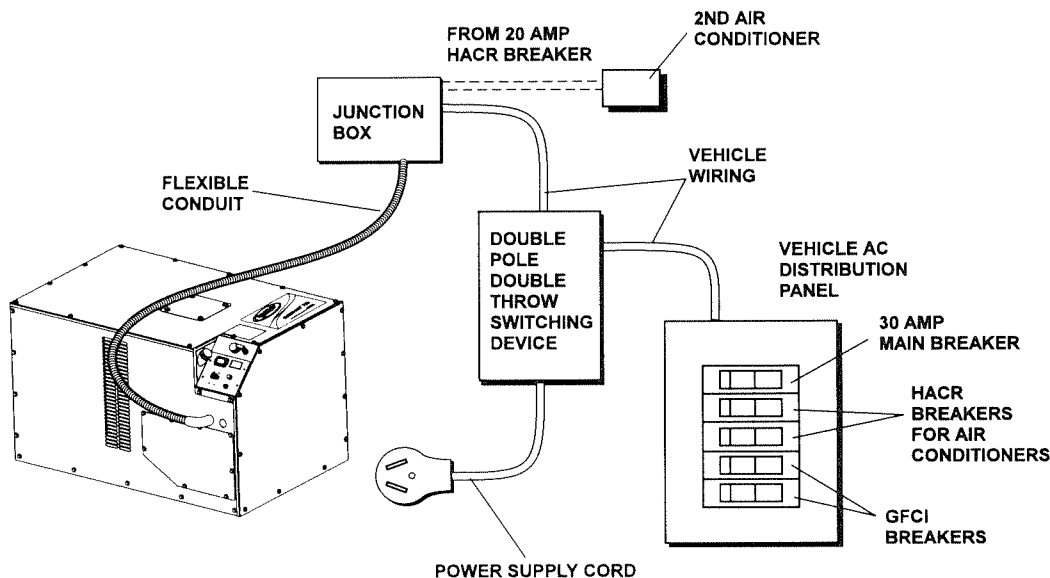
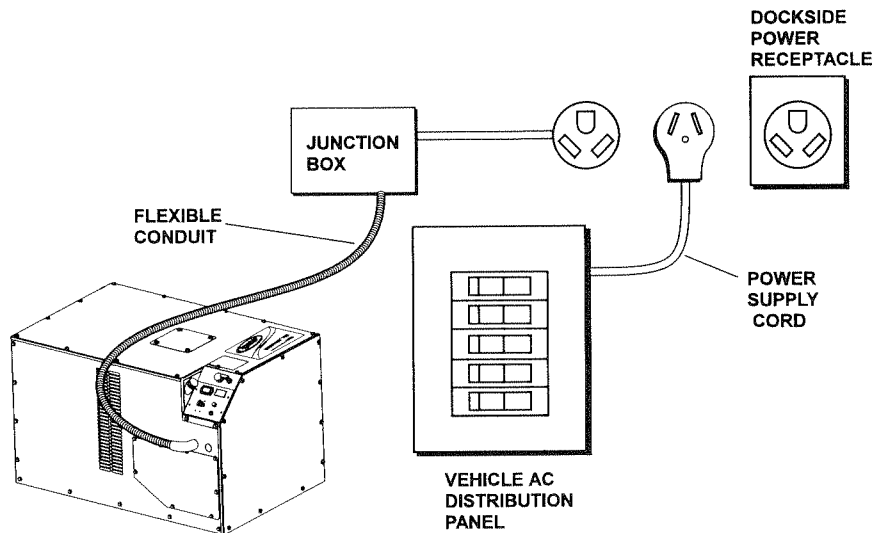

Figure 2.18 – Installation With Isolation Receptacle



2.7 BATTERY INSTALLATION

◆ 2.7.1 RECOMMENDED BATTERY

Install a battery that meets the following requirements:

- The battery must be a 12-volt, automotive type storage battery.
- Use a battery rated 70 amp-hours and capable of delivering 360 cold-cranking amps.

NOTE:

If the battery is to be used to power other vehicle accessories, as well as start the generator, you may need a battery with a larger capacity.

◆ 2.7.2 BATTERY CABLES

Using battery cables that are too long or too small in diameter may cause a drop in voltage, which causes starting problems. For the best cold weather starting, the voltage drop between battery terminals and the generator connection point should not exceed 0.12 volts per 100 amps of cranking current.

QUIETPACT™ generators are rated at about 100 DC amps of cranking current.

Select battery cables based on (a) cable length and (b) prevailing ambient temperatures. Generally, the longer the cable and the colder the weather, the larger the cable size must be, as shown in the chart.

CABLE LENGTH in Feet (meters)	CABLE SIZE
0 to 10 (0 to 3)	2*
11 to 15 (3.4 to 4.5)	0
16 to 20 (4.5 to 6)	000

*For warm weather, use No. 2 cable up to 20 feet.

◆ 2.7.3 BATTERY CABLE CONNECTIONS

1. Connect the battery cable from the battery post or terminal indicated by a POSITIVE, POS or (+) to the insulated lug on the unit frame (Figure 2.19).

NOTE:

Check to be sure the cable boot for the positive cable has been installed.

2. Connect the battery cable from the battery post indicated by a NEGATIVE, NEG or (-) to the vehicle frame ground connection (Figure 2.19).
3. Connect a cable from the vehicle frame ground to the negative post on the generator frame.
4. Connect cables so the connectors are clean and tight.

Figure 2.19 – Connecting Battery Cables

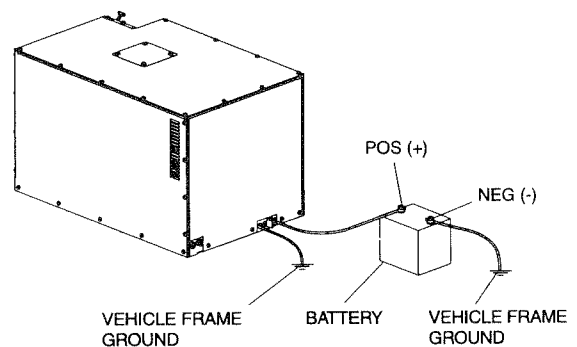

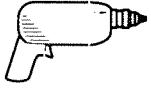

◆ 2.7.4 BATTERY COMPARTMENT

Install the generator battery in its own, vented compartment. Place the battery compartment away from any source of heat, sparks or flame.

Provide ventilation openings in the battery compartment. The minimum size of openings should be 2 square inches at the top of the compartment. Mount the battery on a strong, rigid supporting structure, where leaks and spills of battery fluid will not cause damage.

—▲ DANGER ▲—

▲ Do not dispose of the battery in a fire. The battery is capable of exploding. Storage batteries give off explosive hydrogen gas. This gas can form an explosive mixture around the battery for several hours after charging. The slightest spark can ignite the gas and cause an explosion. Such an explosion can shatter the battery and cause blindness or other injury. Any area that houses a storage battery must be properly ventilated. Do not allow smoking, open flame, sparks, or any spark producing tools or equipment near the battery. Discharge static electricity from your body before touching the battery by first touching a grounded metal surface.

▲ A battery presents a risk of electrical shock and high short circuit current. The following precautions are to be observed when working on batteries:

- Remove watches, rings or other metal objects;
- Use tools with insulated handles;
- Wear rubber gloves and boots;
- Do not lay tools or metal parts on top of the battery;
- Disconnect any charging source prior to connecting or disconnecting battery terminals; and
- Do not use any jumper cables or booster battery to crank and start the generator engine. If any battery has discharged, remove it for recharging.

—▲ WARNING ▲—

▲ Do not open or mutilate the battery. Released electrolyte has been known to be harmful to the skin and eyes, and to be toxic.

▲ The electrolyte is a dilute sulfuric acid that is harmful to the skin and eyes. It is electrically conductive and corrosive. The following procedures are to be observed:

- Wear full eye protection and protective clothing;
- Where electrolyte contacts the skin, wash it off immediately with water.

- Where electrolyte contacts the eyes, flush thoroughly and immediately with water and seek medical attention.
- Spilled electrolyte is to be washed down with an acid neutralizing agent. A common practice is to use a solution of 1 pound (500 grams) bicarbonate of soda to 1 gallon (4 liters) of water. The bicarbonate of soda solution is to be added until the evidence of reaction (foaming) has ceased. The resulting liquid is to be flushed with water and the area dried.

2.8 OPTIONAL ACCESSORIES

A plug-in connector (Figure 2.20) is provided on the generator set, below the control panel. Use this to connect an optional remote-mounted start/stop panel to the generator. Installation of such a panel will permit you to start and stop the generator engine from any convenient location inside the vehicle.

Figure 2.20 – Remote Panel Plug-in Receptacle

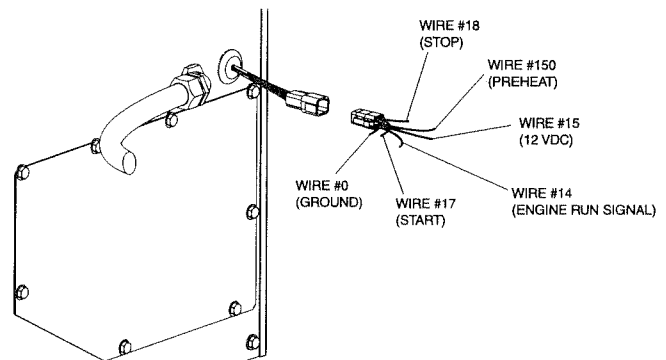

◆ 2.8.1 REMOTE START/STOP CONNECTIONS

The following steps are necessary to connect the remote start/stop option:

1. If the six-wire remote connector is visible below the control panel as shown on Figure 2.20, skip to step 5. Otherwise, proceed with step 2.
2. Remove the electrical access panel located just below the knock-out labeled "REMOTE." The remote connector will be located inside the electrical enclosure along the right side.
3. Remove the "REMOTE" knock-out, taking care not to damage the wiring behind it.
4. Feed the remote connector through the hole and fit the supplied grommet into position.
5. Wire the remote harness (Part # C6712C, supplied as an accessory with the generator) to the coach's remote start panel. Refer to Figure 2.20 for a wiring legend.
6. Plug the remote harness into the mating remote connector on the generator.

3.1 POST INSTALLATION TESTS

The generator set was factory tested and adjusted. You should not be required to adjust the unit any further except under special circumstances.

▲ WARNING ▲

- ▲ Do not make any unnecessary adjustments. Factory settings are correct for most applications. When making adjustments, however, be careful to avoid overspeeding the engine.

3.2 BEFORE INITIAL START-UP

Before starting, complete the following:

1. Check the engine crankcase oil level and, if necessary, fill to the dipstick "FULL" mark (cross-hatched area) with the recommended oil. Do not fill above the FULL mark.
2. Check the fuel supply. Fuel lines must have been properly purged and leak tested in accordance with applicable fuel codes. All fuel shutoff valves in the fuel supply lines must be open.

3.3 INITIAL START

When you are absolutely certain that the unit has been properly installed and prepared for use, start the engine as follows:

1. Turn off all electrical loads. Do this by setting the generator's line breakers to their "OFF" (or open) position.
2. Refer to Part I, Section 2.4, "Starting the Generator" (Page 8), for cranking and starting instructions. The engine may require more cranking for initial starting since the fuel lines have to be primed (use of the preheat switch will operate the generator's electrical fuel pump and shorten this time).
3. Let the engine warm up for about five minutes to allow internal temperatures to stabilize.
4. Carefully inspect the engine/generator for fuel, oil and exhaust system leaks. Before proceeding to the next step, correct any leakage immediately.

5. When all tests and adjustments at no-load are completed, apply electrical loads and check for proper operation under load. See Section 3.4. Run the unit at least 30 minutes with loads applied.
6. Turn off all electrical loads by setting the generator's line breakers to their "OFF" (or open) position.
7. Let the unit run at no-load for a few minutes to stabilize internal engine/generator temperatures. Then, shut down the engine.

NOTE:

The generator set was thoroughly tested and adjusted at the factory before shipping. No additional adjustment should be necessary. Only qualified service technicians who have been trained should perform adjustments outlined in this manual.

3.4 TESTING UNDER LOAD

Apply electrical loads equal to about 50 to 75 percent of the unit's rated wattage/amperage capacity.

Let the unit run at least 30 minutes with load applied. During this part of the test, check that the unit is not running excessively hot and that adequate cooling airflow is available. You must not allow the unit to overheat during prolonged operation.

NOTE:

The generator engine is equipped with a high coolant temperature switch. The switch has normally open (N.O.) contacts. When the engine coolant temperature is too high, switch contacts close, and the engine shuts down automatically.

GENERAC RECOMMENDS THAT YOU TEST THE GENERATOR FOR ADEQUATE COOLING.

3.5 INSTALLATION CHECKLIST

◆ LOCATION AND SUPPORT

- Generator is properly located.
- Generator is properly supported.
- Generator is properly restrained.

◆ GENERATOR COMPARTMENT

- Compartment construction is proper.
- Holes/Openings are vapor-sealed.
- Compartment size is correct.
- Compartment is vapor-sealed.
- Sound insulation is correct.
- Floor cutouts are properly completed.

◆ COOLING AND VENTILATING AIR

- Airflow is adequate.
- Air inlet opening is correct.
- Compensate for restrictions.
- Check that installation has been tested.

◆ DIESEL FUEL SYSTEM

- Fuel tank complies with all applicable codes.
- Fuel system is properly installed and checked for leaks.

◆ EXHAUST SYSTEM

- Exhaust system complies with all applicable codes.
- Exhaust system is properly and safely installed.

◆ ELECTRICAL CONNECTIONS

- Connections comply with local code requirements and all National Electrical Codes.
- Junction box is properly installed.
- Wiring meets all standards.
- All connections are correct.
- Conduit is properly installed and sealed.
- Generator is properly bonded to the vehicle.

◆ BATTERY INSTALLATION

- Recommended battery is installed.
- Recommended cables are installed.
- Cables are clean and tight.
- Cables are connected properly.
- Proper ventilation is provided.
- Terminals are coated with anti-corrosion grease, and terminal covers are positioned.

◆ OPTIONAL ACCESSORIES

- Check that remote start/stop panels (if used) are installed properly.
- Check that any other options and accessories (if used) are installed properly.

◆ POST INSTALLATION TESTS

- Check that all tests are completed properly.

DATE OF INSTALLATION _____

NAME OF INSTALLER _____

SIGNATURE OF INSTALLER _____



TROUBLESHOOTING GUIDE

PROBLEM	CAUSE	CORRECTION
The engine will not crank.	<ol style="list-style-type: none"> 1. System control fuse blown 2. Loose corroded or defective battery cables 3. Defective engine Start/Stop switch 4. Defective starter contactor 5. Defective starter motor 6. Low or defective battery 7. Defective engine control board 	<ol style="list-style-type: none"> 1. Replace fuse. 2. Tighten, clean or replace as necessary. 3. Replace Start/Stop switch. 4. Replace contactor. 5. Replace starter motor. 6. Charge or replace battery. 7. Replace control board.
The engine cranks but will not start.	<ol style="list-style-type: none"> 1. Vehicle fuel shutoff valve closed 2. Out of fuel 3. Defective fuel solenoid (FS) 4. Defective fuel pump (FP) 5. Open #14 wire from engine control board 6. Plugged fuel filter or fuel line 7. Engine mechanical parts failure 8. Defective engine control board 	<ol style="list-style-type: none"> 1. Open valve, if so equipped. 2. Replenish fuel. 3. Replace solenoid. 4. Repair or replace fuel pump. 5. Check connections and insulation of #14 wires. 6. Clean or replace fuel filter or line. 7. Repair or replace parts. 8. Replace control board.
The engine starts hard and runs rough.	<ol style="list-style-type: none"> 1. Air filter plugged or damaged 2. Defective fuel pump (FP) 3. Plugged fuel filter or fuel line 4. Water in fuel 5. Improper preheat 	<ol style="list-style-type: none"> 1. Check, clean or replace as needed. 2. Repair or replace fuel pump. 3. Clean or replace fuel filter or line. 4. Drain fuel system and refill. 5. Preheat unit.
The engine starts, but shuts down when the Start/Stop switch is released.	<ol style="list-style-type: none"> 1. Engine oil level low 2. Overheated engine 3. Defective low oil pressure switch 4. Defective high coolant temperature switch 5. Defective engine control board 	<ol style="list-style-type: none"> 1. Check oil and add oil as needed. 2. Check cooling system for leaks. 3. Replace pressure switch. 4. Replace temperature switch. 5. Replace control board.
The Start/Stop switch is set to Stop, but the engine continues to run.	<ol style="list-style-type: none"> 1. Defective Start/Stop switch 2. Open/Disconnected #18 wire between Start/Stop switch and engine control board 3. Open/Disconnected #0 wire between Start/Stop switch and engine control board 4. Defective engine control board 	<ol style="list-style-type: none"> 1. Replace switch. 2. Reconnect or close wire. 3. Reconnect or close wire. 4. Replace control board.
There is no AC output from the generator.	<ol style="list-style-type: none"> 1. Main line circuit breaker open 2. Fault with vehicle circuit breaker and/or fuses 3. Generator internal failure 	<ol style="list-style-type: none"> 1. Reset line breaker to ON (or closed). 2. Reset and replace if necessary. 3. Contact a Generac Authorized Service Dealer.

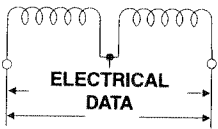

Appendix 2 – Electrical Data

QUIETPACT™ 75D Recreational Vehicle Generator Wiring Diagram – Drawing No. C4946-

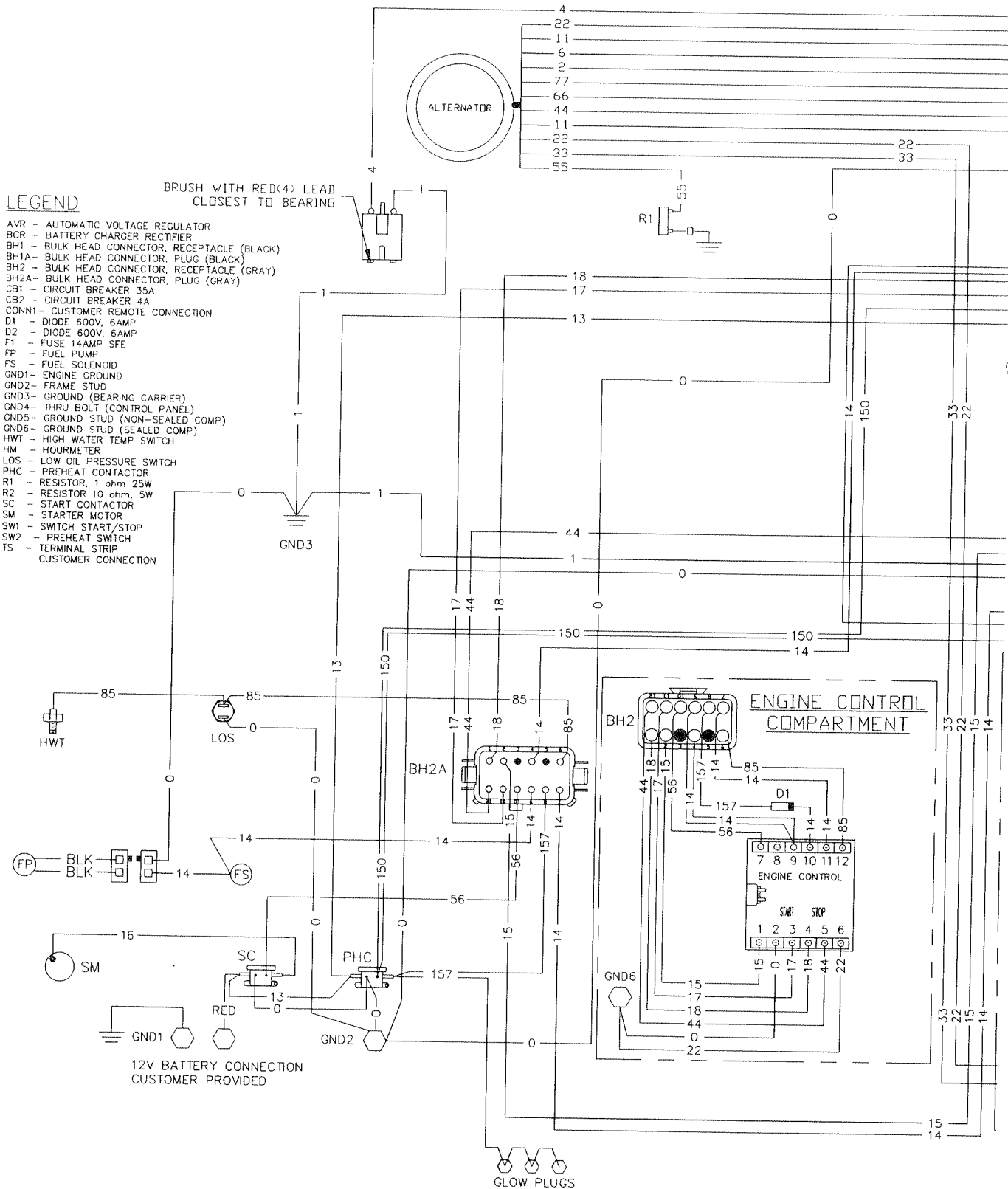

Appendix 2 – Electrical Data
QUIETPACT™ 75D Recreational Vehicle Generator
Wiring Diagram – Drawing No. C4946-

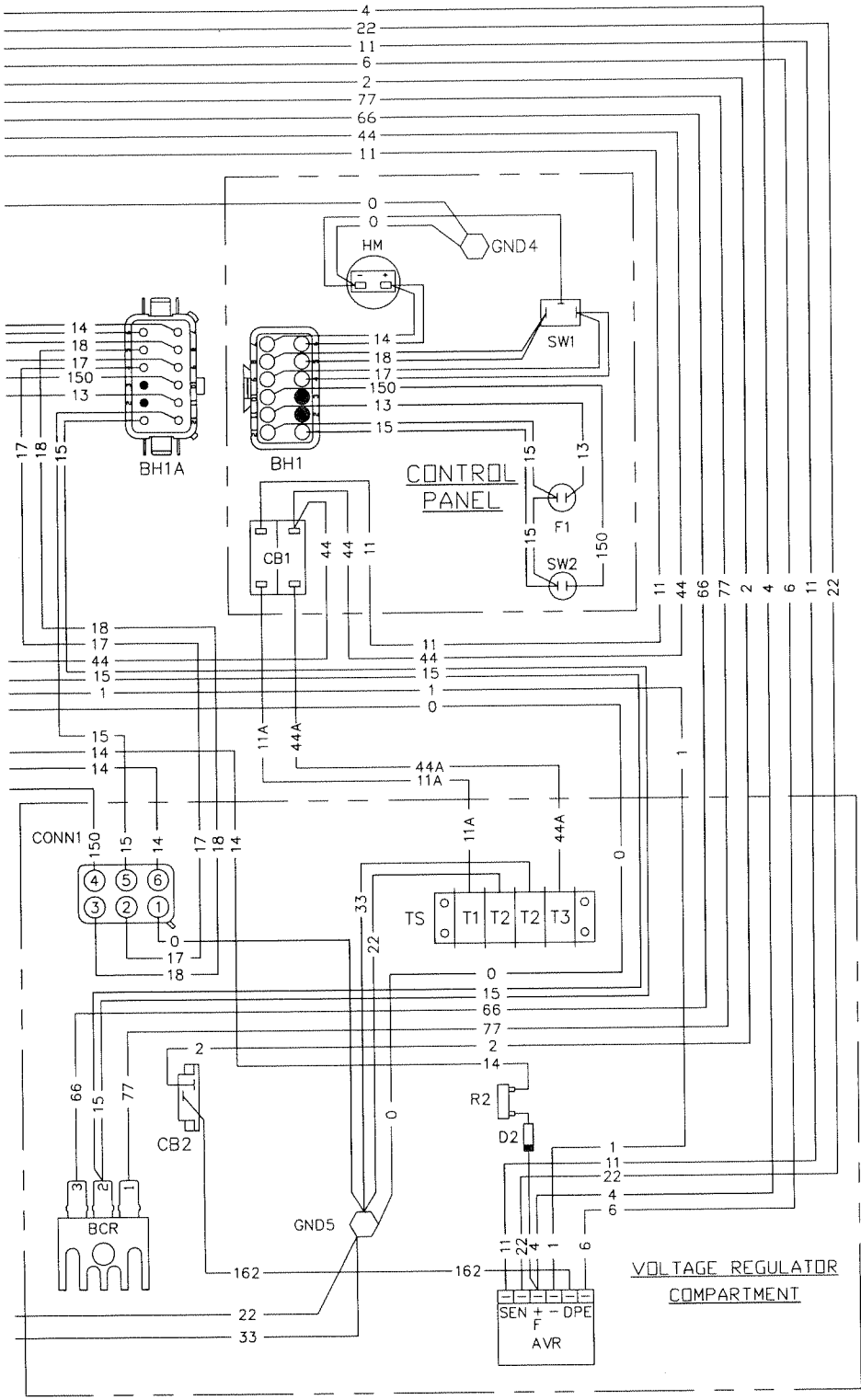
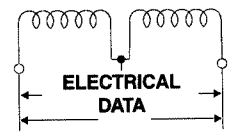

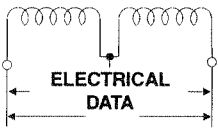

Appendix 2 – Electrical Data

QUIETPACT™ 75D Recreational Vehicle Generator Electrical Schematic – Drawing No. - C4945

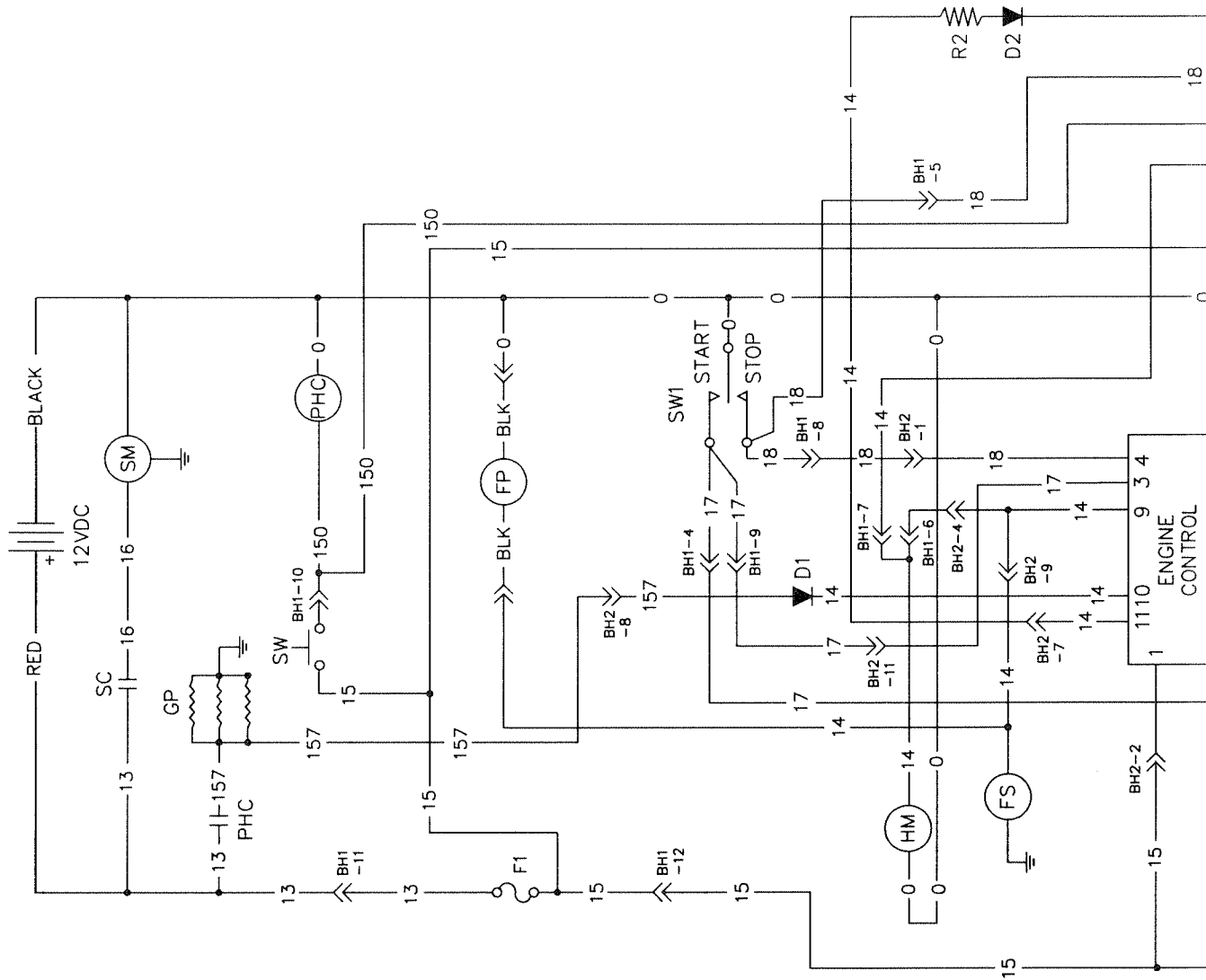

LEGEND

AVR –AUTOMATIC VOLTAGE REGULATOR
 BCR –BATTERY CHARGE RECTIFIER
 BCW –BATTERY CHARGER
 CB1 –CIRCUIT BREAKER 35A
 CB2 –CIRCUIT BREAKER (4A)
 D1 –DIODE 600V, 6AMP
 D2 –DIODE 600V, 6AMP
 DPE –EXCITATION WINDING
 F1 –FUSE 14AMP SFE
 FS –FUEL SOLENOID
 FP –FUEL PUMP
 GP –GLOW PLUGS
 HM –HOURMETER

HWT –HIGH WATER TEMP SWITCH
 LOS –LOW OIL PRESSURE SWITCH
 PHC –PREHEAT CONTACTOR
 R1 –RESISTOR, 1 OHM, 25W
 R2 –RESISTOR 10 OHM, 5W
 S –STARTER
 SC –START CONTACTOR
 SW –PREHEAT SWITCH
 SW1 –SWITCH, START/STOP

Appendix 2 – Electrical Data
QUIETPACT™ 75D Recreational Vehicle Generator
Electrical Schematic – Drawing No. - C4945

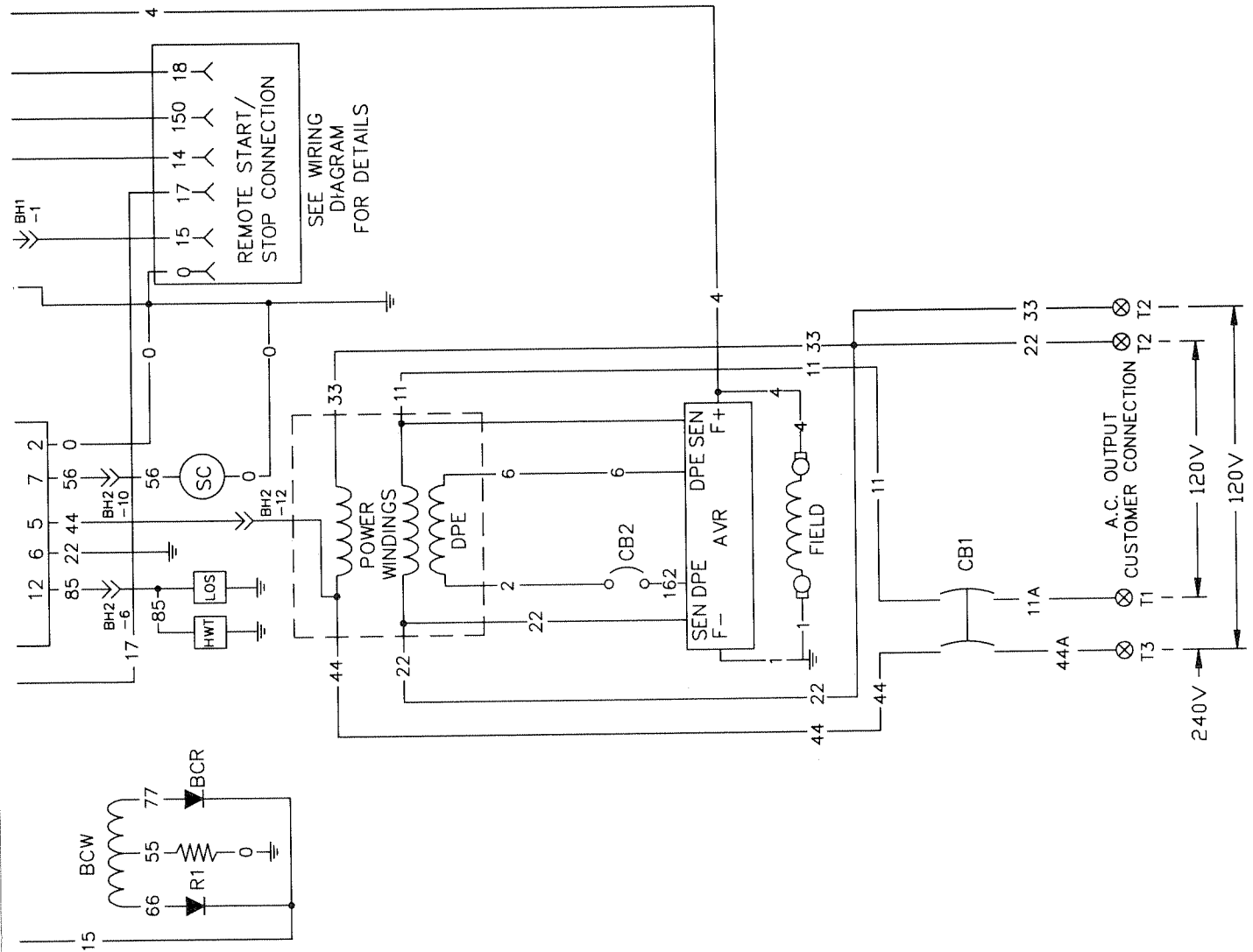
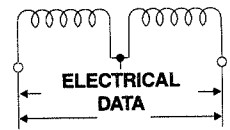

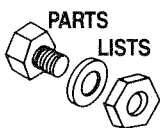

Appendix 3 – Exploded Views and Parts Lists

QUIETPACT™ 75D Recreational Vehicle Generator
 Engine, Alternator Drive and Starter Assembly – Drawing No. C7651

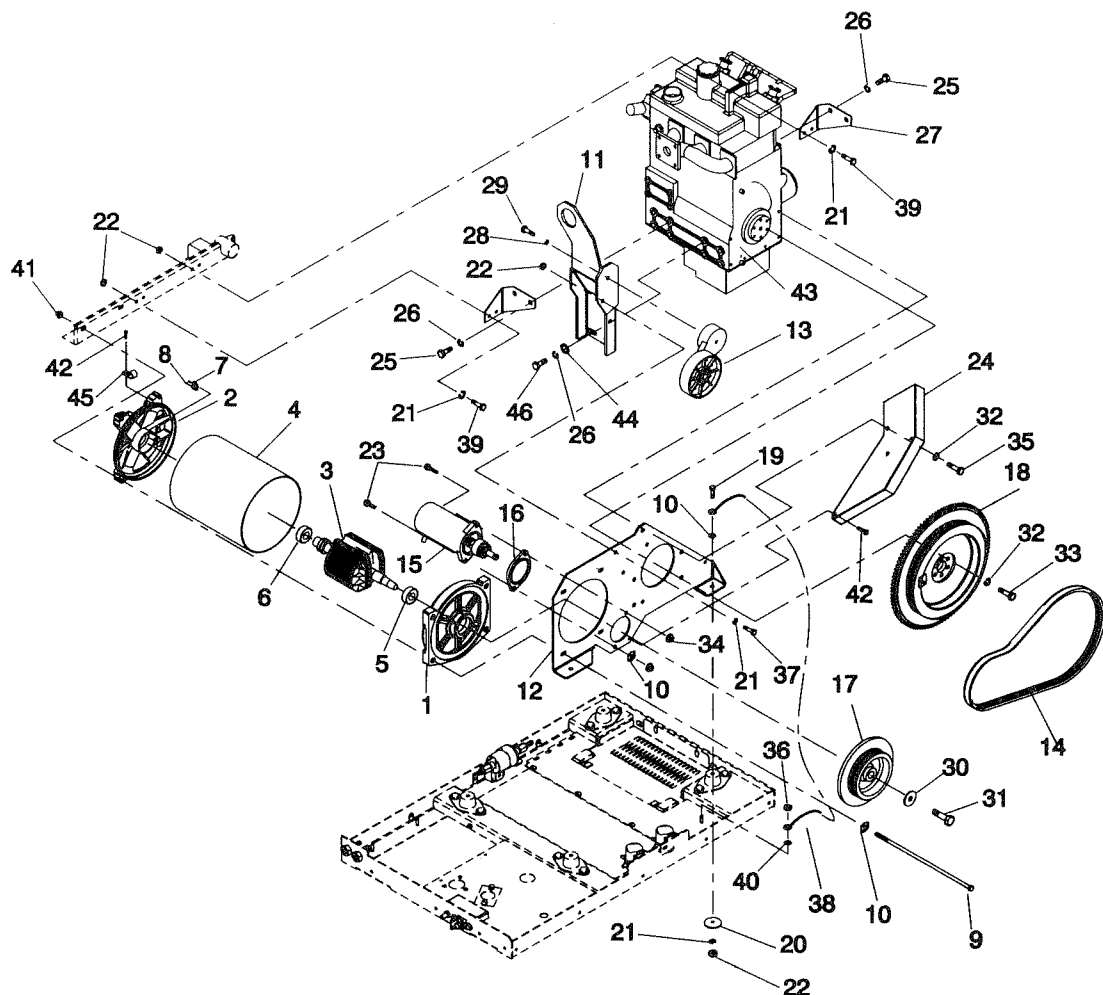

ITEM	PART NO.	QTY.	DESCRIPTION	ITEM	PART NO.	QTY.	DESCRIPTION
1	C5598	1	BEARING CARRIER, FRONT	24	C7933	1	GUARD, FLYWHEEL
2	72379B	1	BEARING CARRIER, UPPER	25	68485	4	HHCS M12-1.25 X 20
3	C6055H	1	ROTOR ASSEMBLY	26	51769	6	WASHER, SPLIT LK -M12
4	C6054H	1	STATOR ASSEMBLY	27	C4537	2	ENGINE BRACKET
5	31971	1	BALL BEARING	28	22237	1	WASHER, SPLIT LK -3/8
6	73159	1	BALL BEARING	29	22511	1	HHCS 3/8-16 X 11/2
7	66386	1	BRUSH HOLDER	30	49451	1	FENDER WASHER 7GA
8	66849	2	TAPTITE M5-0.8 X 16	31	42633	1	HHCS 3/8-24 X 1"
9	C6862	4	BOLT , STATOR	32	46526	11	LOCKWASHER M10
10	C3168	6	5/16 SPECIAL LOCK WASHER	33	52212	6	HHCS M10-1.25 X 25
11	C5014	1	LUG, LIFT	34	69673J	2	5/16 FLANGE NUT
12	C4538	1	RAIL, ENGINE RH	35	51756	5	HHCS M10-1.25 X 20
13	C4544	1	ROTARY TENSIONER 4.5"	36	49813	1	M6 HEX NUT
14	C5298	1	BELT, V-RIB	37	43107	2	HHCS M8-1.25 X 25
15	20692	1	STARTER MOTOR	38	21991	1	EARTH STRAP
16	C4841	1	SPACER, STARTER	39	39253	4	HHCS M8-1.25 X 20
17	73106G	1	PULLEY, ALTERNATOR	40	A1658	1	1/4 SPECIAL LOCK WASHER
18	C6363	1	FLYWHEEL ASSEMBLY	41	67989	4	M8 FLANGE NUT
19	39288	2	HHCS M8-1.25 X 55	42	C1069	3	TAPTITE, M6-1.0 X 8
20	71956	2	WASHER, VIBRATION ISOLATOR	43	C6609	1	ENGINE, 1.0L DIESEL
21	22129	8	WASHER, SPLIT LK -M8	44	49808	2	WASHER, FLAT M12
22	45771	8	NUT, HEX M8-1.25	45	55934M	1	CLAMP, VINYL COATED, 3/4
23	40250	2	SHCS 5/16-18 X 11/2	46	A7043	2	HHCS M12-1.25 X 25

Appendix 3 – Exploded Views and Parts Lists

QUIETPACT™ 75D Recreational Vehicle Generator Base Frame – Drawing No. C7652

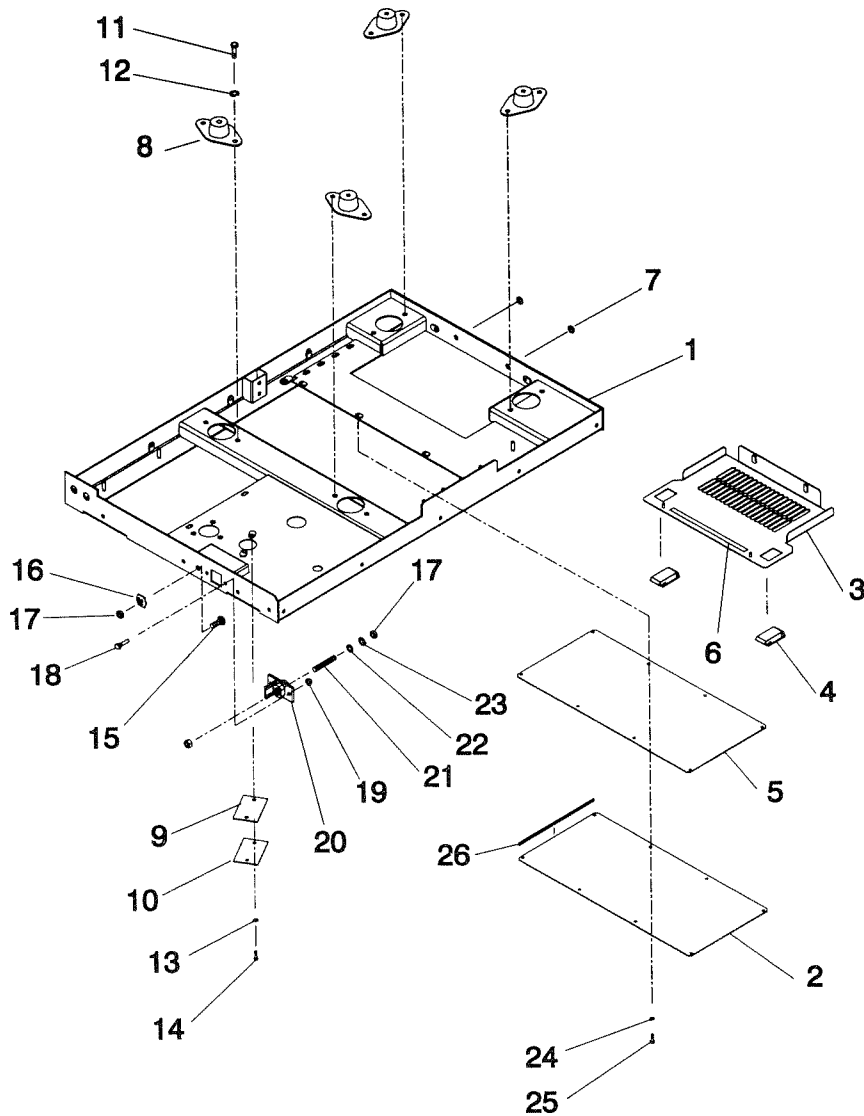
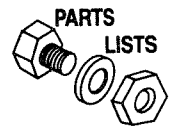

ITEM	PART NO.	QTY.	DESCRIPTION
1	C6950	1	BASE FRAME WELDMENT
2	C5087	1	DOOR, SERVICE REAR
3	C5088	1	DOOR, SERVICE FRONT
4	C5644	2	SLIDE LATCH FLUSH
5	C5712	1	GASKET, SERVICE DOOR REAR
6	29451	220MM	RUBBER TAPE 1/8 X 1/2"
7	C7857	2	GROMMET 1/8 X 13/32
8	70936	4	VIBRATION MOUNT
9	C6721	1	GASKET, CLEANOUT
10	C6722	1	PLATE, CLEANOUT
11	42907	8	HHCS M8-1.25 X 16
12	22129	8	WASHER, SPLIT LK- M8
13	22097	1	WASHER, SPLIT LK -1/4-M6
14	43146	2	HHCS M6-1.00 X 10
15	C7561	1	CARRIAGE BOLT 3/8 -16 X 55MM

ITEM	PART NO.	QTY.	DESCRIPTION
16	A4456	1	3/8 SPECIAL LOCK WASHER
17	76821	2	HEX NUT 3/8-16 BRASS
18	47411	2	HHCS M6-1.00 X 16
19	52857	2	NUT, LOCKING M6.0 -1
20	C5443	1	BLOCK, TERMINAL BATTERY POST
21	C7423	1	STUD 3/8-16 X 55MM
22	22131	1	WASHER 3/8 FLAT
23	22237	1	WASHER SPLIT LK -3/8
24	22264	8	LOCKWASHER #8 -M4
25	51718	8	HHCS M4-0.7 X 10
26	56326	2	VINYL TRIM -BLACK 180MM

MM = MILLIMETRES

Appendix 3 – Exploded Views and Parts Lists

**QUIETPACT™ 75D Recreational Vehicle Generator
Enclosure – Drawing No. C7653**

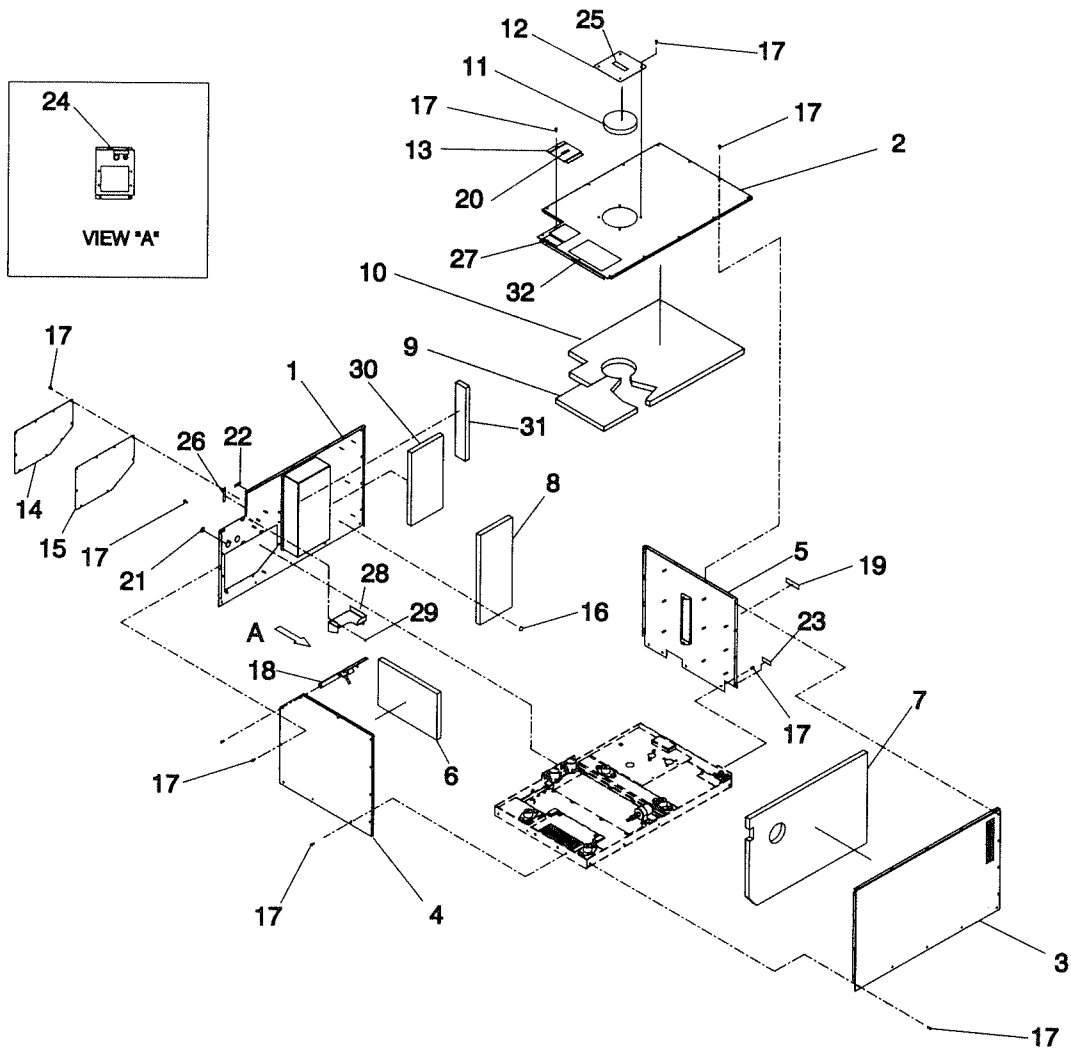

ITEM	PART NO.	QTY.	DESCRIPTION	ITEM	PART NO.	QTY.	DESCRIPTION
1	C5607	1	ENCLOSURE PANEL RH	18	C5096	1	FRAME CONTROL PANEL - REFER TO DRAWING C8005
2	C4534	1	ENCLOSURE PANEL TOP	19	C7023	1	DECAL, BATTERY +/-
3	C4532	1	ENCLOSURE PANEL LH	20	C7024	1	DECAL, RADIATOR CAP
4	C4535	1	ENCLOSURE PANEL FRONT	21	C7025	1	DECAL, REMOTE
5	C4536	1	ENCLOSURE REAR PANEL	22	C7026	1	DECAL, COOLANT
6	C5525	1	INSULATION, FRONT PANEL	23	C7027	1	DECAL, FUEL RETURN/SUPPLY
7	C5527	1	INSULATION, LH SIDE PANEL	24	C7028	1	DECAL, OIL FILL / LEVEL
8	C5528	1	INSULATION, RH SIDE PANEL	25	C7029	1	DECAL, LIFTING LUG
9	C5529	1	INSULATION, TOP FRONT PANEL	26	C7030	1	DECAL, MAX HOT / MIN COOLANT
10	C5530	1	INSULATION, TOP REAR PANEL	27	C2340	1	DECAL, WARNING RV
11	C5531	1	INSULATION, LIFTING LUG COVER	28	C6425	1	SUPPORT, COOLANT TANK
12	C4986	1	COVER, ACCES LIFT	29	52857	3	NUT, LOCKING M6-1
13	C4987	1	COVER, RADIATOR FILL	30	C7047A	1	FOAM, AIR DUCT FACE
14	C5091	1	COVER, ACCESS ELECTRICAL	31	C7047B	1	FOAM, AIR DUCT SIDE
15	C6362	1	GASKET, ELECTRICAL ACCESS	32	C4816	1	DECAL, UNIT
16	78115	33	WASHER, SELF LOCK DOME				
17	A7215	58	¼ -20 X 5/8 W/WASHER				

Appendix 3 – Exploded Views and Parts Lists

QUIETPACT™ 75D Recreational Vehicle Generator Base Frame – Drawing No. C7652-B

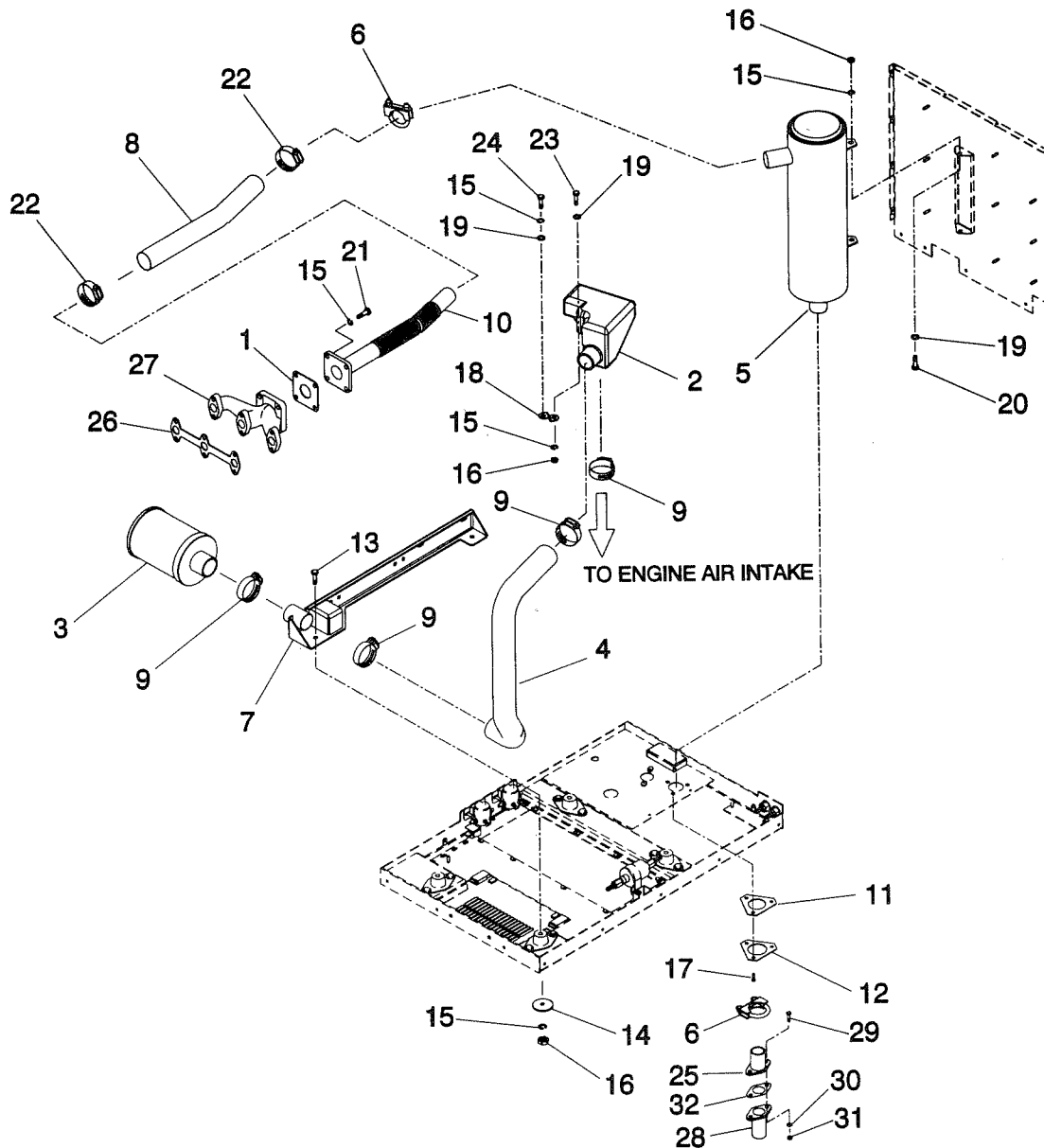
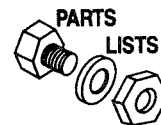

ITEM	PART NO.	QTY.	DESCRIPTION
1	C6950	1	BASE FRAME WELDMENT
2	C5087	1	DOOR, SERVICE REAR
3	C5088	1	DOOR, SERVICE FRONT
4	C5644	2	SLIDE LATCH FLUSH
5	C5712	1	GASKET, SERVICE DOOR REAR
6	29451	220MM	RUBBER TAPE 1/8 X 1/2"
7	C7857	2	GROMMET 1/8 X 13/32
8	70936D	4	VIBRATION MOUNT
9	C6721	1	GASKET, CLEANOUT
10	C6722	1	PLATE, CLEANOUT
11	42907	8	HHCS M8-1.25 X 16
12	22129	8	WASHER, SPLIT LK- M8
13	22097	3	WASHER, SPLIT LK -1/4-M6
14	43146	2	HHCS M6-1.00 X 10
15	C7561	1	CARRIAGE BOLT 3/8 -16 X 55MM

ITEM	PART NO.	QTY.	DESCRIPTION
16	A4456	1	3/8 SPECIAL LOCK WASHER
17	76821	2	HEX NUT 3/8-16 BRASS
18	47411	2	HHCS M6-1.00 X 16
19	49813	2	NUT, HEX M6.0 -1.0
20	C5443	1	BLOCK, TERMINAL BATTERY POST
21	C7423	1	STUD 3/8-16 X 55MM
22	22131	1	WASHER 3/8 FLAT
23	22237	1	WASHER SPLIT LK -3/8
24	22264	8	LOCKWASHER #8 -M4
25	51718	8	HHCS M4-0.7 X 10
26	56326	2	VINYL TRIM -BLACK 180MM

MM = MILLIMETERS

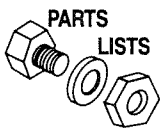

Appendix 3 – Exploded Views and Parts Lists

QUIETPACT™ 75D Recreational Vehicle Generator
Enclosure – Drawing No. C7653-A

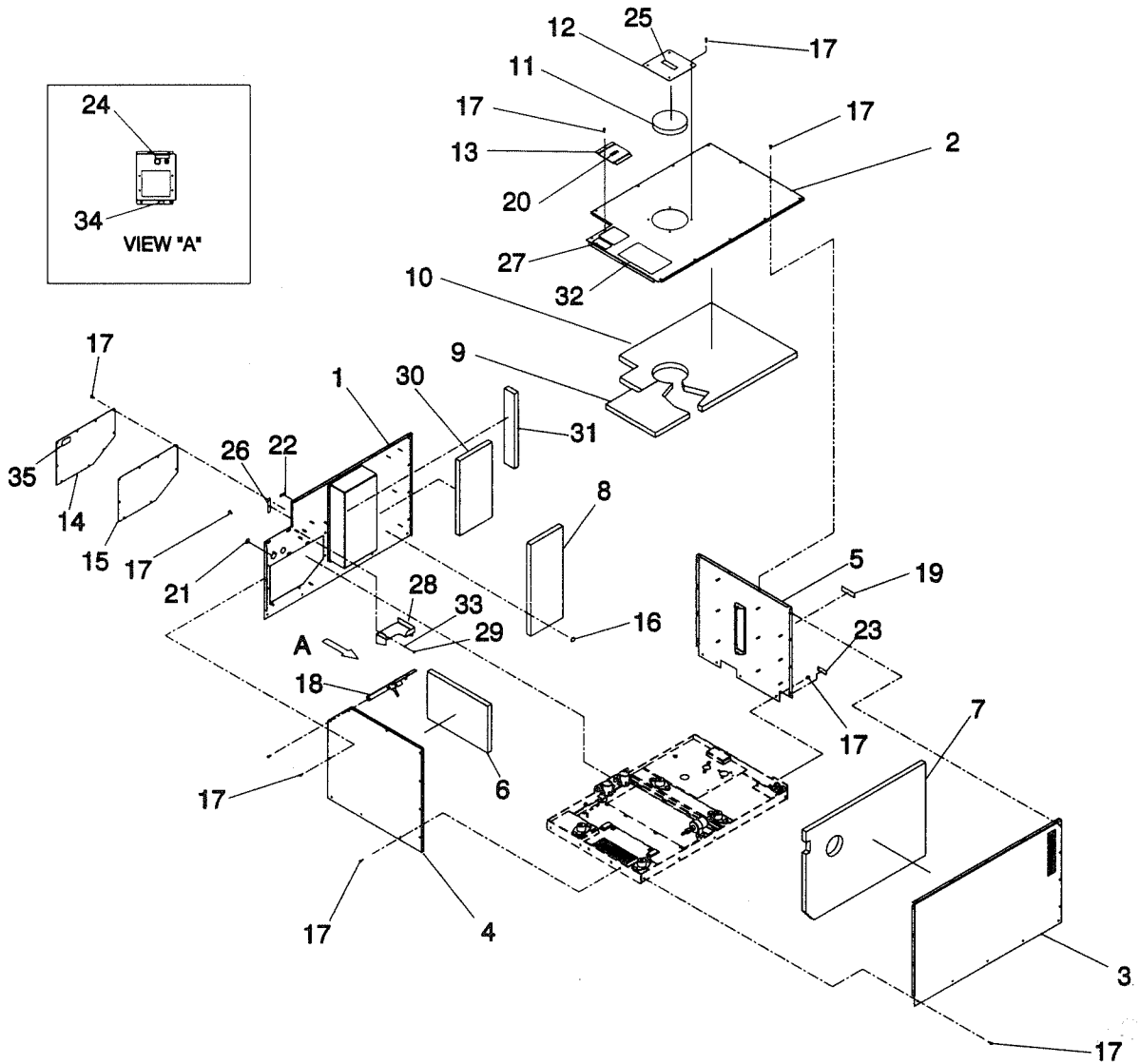

ITEM	PART NO.	QTY.	DESCRIPTION	ITEM	PART NO.	QTY.	DESCRIPTION
1	C5607	1	ENCLOSURE PANEL RH	19	C7023	1	DECAL, BATTERY +/-
2	C4534	1	ENCLOSURE PANEL TOP	20	C7024	1	DECAL, RADIATOR CAP
3	C4532	1	ENCLOSURE PANEL LH	21	C7025	1	DECAL, REMOTE
4	C4535	1	ENCLOSURE PANEL FRONT	22	C7026	1	DECAL, COOLANT
5	C4536	1	ENCLOSURE REAR PANEL	23	C7027	1	DECAL, FUEL RETURN/SUPPLY
6	C5525	1	INSULATION, FRONT PANEL	24	C7028	1	DECAL, OIL FILL / LEVEL
7	C5527	1	INSULATION, LH SIDE PANEL	25	C7029	1	DECAL, LIFTING LUG
8	C5528	1	INSULATION, RH SIDE PANEL	26	C7030	1	DECAL, MAX HOT / MIN COOLANT
9	C5529	1	INSULATION, TOP FRONT PANEL	27	C2340	1	DECAL, WARNING RV
10	C5530	1	INSULATION, TOP REAR PANEL	28	C6425	1	SUPPORT, COOLANT TANK
11	C5531	1	INSULATION, LIFTING LUG COVER	29	49813	3	NUT, HEX M6-1.0
12	C4986	1	COVER, ACCESS LIFT	30	C7047A	1	FOAM, AIR DUCT FACE
13	C4987	1	COVER, RADIATOR FILL	31	C7047B	1	FOAM, AIR DUCT SIDE
14	C5091	1	COVER, ACCESS ELECTRICAL	32	C4816	1	DECAL, UNIT
15	C6362	1	GASKET, ELECTRICAL ACCESS	33	22097	3	WASHER, SPLIT LOCK 1/4" - M6
16	78115	33	WASHER, SELF LOCK DOME	34	98761	1	DECAL, ENGINE DATA
17	A7215	58	1/4" -20 X 5/8 W/WASHER	35	42755	1	DECAL, CSA APPROVAL
18	C5096	1	FRAME CONTROL PANEL - REFER TO DRAWING C8005				

Appendix 3 – Exploded Views and Parts Lists

QUIETPACT™ 75D Recreational Vehicle Generator Cooling System – Drawing No. C7654-B

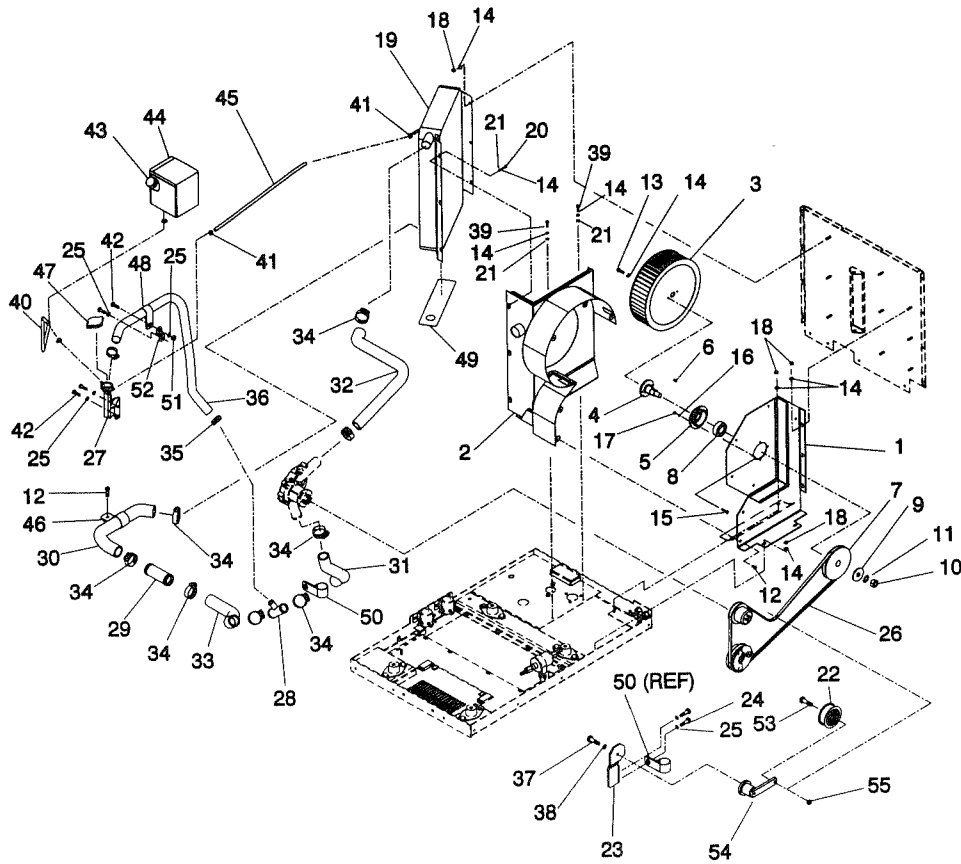
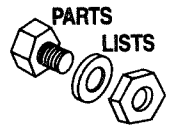

ITEM	PART NO.	QTY.	DESCRIPTION
1	C4551	1	COVER PLATE, SCROLL WELDMENT
2	C4550	1	HOUSING, FAN SCROLL WELDMENT
3	C4552	1	FAN, SQUIRREL CAGE
4	C4554	1	SHAFT, FAN
5	C4555	1	CARRIER, BEARING
6	C4557	1	KEY, SQUARE 3/16 X 3/16 X 1/2
7	C4556	1	PULLEY, FAN 4 7/8
8	C4553	1	BEARING 2 ROW BALL
9	49869	1	FENDER WASHER M16
10	81810	1	NUT, HEX M16.0 -1.5MM
11	70265	1	LOCKWASHER M16.0
12	58443	7	CRIMPTITE, 1/4"-20 X 5/8"
13	43146	2	HHCS M6-1.00 X 10MM
14	22097	19	WASHER, SPLIT LK 1/4- M6
15	49815	4	HHCS M5-0.8 X 16MM
16	22152	4	WASHER, SPLIT LK #10
17	51716	4	HEX NUT M5
18	49813	12	NUT, HEX M6.0 -1.0MM
19	C4312	1	RADIATOR 1.0L RV
20	43116	3	HHCS M6-1.00 X 12MM
21	22473	5	WASHER 1/4-M6
22	C8643	1	PULLEY, 3" FLAT FLANGED
23	C8507	1	BRACKET, ROTARY TENSIONER
24	39253	2	HHCS M8-1.25 X 20
25	22129	6	WASHER, SPLIT LK -M8
26	C6549A	1	61" GREEN BELT
27	C5108	1	FILLER NECK ASSEMBLY, RADIATOR REMOTE

ITEM	PART NO.	QTY.	DESCRIPTION
28	C6236	1	HOSE TEE
29	C7384	1	COUPLING, HOSE
30	C5543	1	HOSE, RADIATOR LOWER
31	C4460	1	HOSE, WATER PUMP LOWER
32	C4845	1	HOSE, TOP
33	C5544	1	HOSE, LOWER INTERMEDIATE
34	86133A	8	HOSE CLAMP HI TRQ 1-3/4 MAX
35	57822	2	HOSE CLAMP #8
36	50968	720MM	HOSE, 3/4 SAE-20R3
37	42911	1	M10-1.5 X 30MM HHCS
38	46526	1	M10 LOCKWASHER
39	47411	2	HHCS M6-1.00 X 16MM
40	C7997	270MM	HOSE, 5/16 SAE-20R4
41	C7649	4	HOSE CLAMP 7/8 3/8
42	42907	4	HHCS M8-1.25 X 16MM
43	C5605	1	CAP, COOLANT FILL
44	C6976	1	TANK, COOLANT OVERFLOW
45	C7997	510MM	HOSE 5/16 SAE-20R4
46	55934K	1	CLAMP, VINYL COATED 1 5/8
47	C4976	1	CAP, RADIATOR PRESSURE
48	55934D	1	CLAMP, VINYL COATED 1 1/16
49	C7040	1	GASKET, RADIATOR BASE
50	55934V	1	CLAMP, VINYL COATED 1 1/2
51	45771	1	NUT, HEX M8-1.25
52	C5105	1	BRACKET, SUPPORT
53	24426	1	1/2"-13 X 1-3/4" HHCS
54	C8643	1	TENSIONER, SE-18-3"
55	48705	1	1/2" - 13 FLANGE NUT

MM = MILLIMETERS

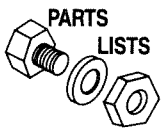

Appendix 3 – Exploded Views and Parts Lists

QUIETPACT™ 75D Recreational Vehicle Generator Electrical Enclosure Assembly – Drawing No. C7655-B

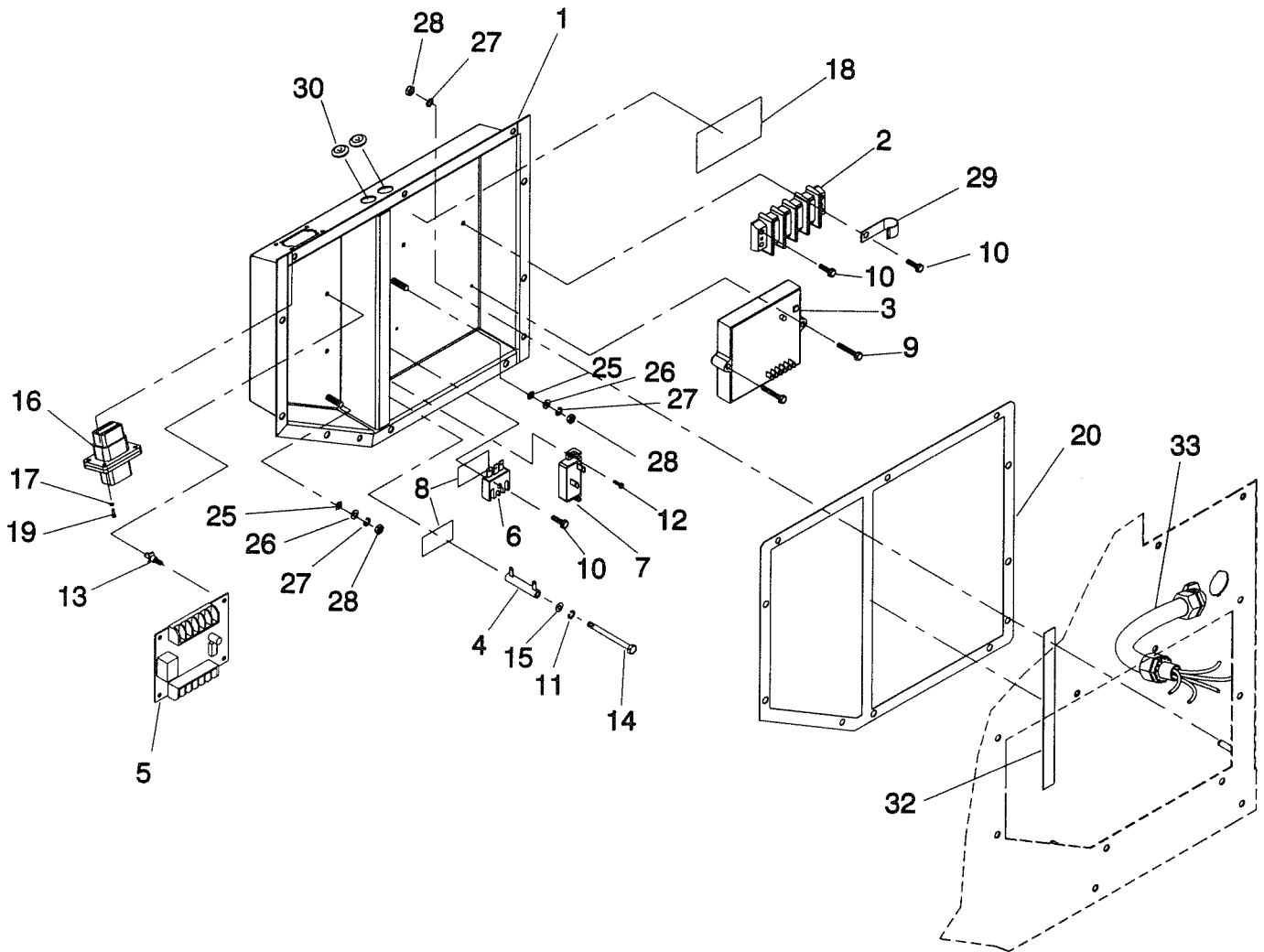

ITEM	PART NO.	QTY.	DESCRIPTION
1	C6878	1	WELDMENT, ELECTRICAL ENCLOSURE
2	71914	1	TERMINAL BLOCK 4 POSITION
3	83048	1	ASSEMBLY, POTTED REGULATOR
4	C7610	1	RESISTOR 20R 5% 12W
5	93642	1	ASSEMBLY MARINE CONTROL BOARD
6	65795	1	RECTIFIER, BATTERY CHARGING
7	48512	1	CIRCUIT BREAKER 5 AMP
8	27565	A/R	TAPE, GLASS INSULATED
9	66849C	2	TAPTITE, M5-0.8 X 30
10	66849	3	TAPTITE, M5-0.8 X 16
11	49226	1	LOCKWASHER M5
12	33134	2	HHMS, #6-32 X 1/2"
13	40213	4	PCB SUPPORT SNAP -IN
14	C8620	1	HHMS, #8-32 X 2.25"
15	51713	1	WASHER, FLAT M5
16	C6712A	1	HARNESS
17	22985	4	WAHSER, FLAT #6
18	C7022	1	DECAL, CUSTOMER CONNECTION

ITEM	PART NO.	QTY.	DESCRIPTION
19	C3992	4	TAPTITE, SCREW
20	C6359	1	GASKET, ELECTRICAL ENCLOSURE
21	C6712G*	1	WIRE ASSEMBLY # 32
22	C6712F*	1	WIRE ASSEMBLY # 22
23	C6712D*	1	DIODE ASSEMBLY
24	C6712E*	1	WIRE ASSEMBLY # 162
25	A1658	2	1/4 SPECIAL LOCKWASHER
26	22473	2	WASHER, FLAT 1/4-M6
27	22097	7	WASHER, SPLIT LK 1/4-M6
28	49813	7	NUT, HEX M6-1
29	82121A	1	CLAMP, OPEN TYPE
30	22717B	2	GROMMET
32	C7390	1	GASKET, ELECTRICAL ENCLOSURE DIVIDER
33	C7487	1	HARNESS, AC OUTPUT

A/R = AS REQUIRED

* NOT SHOWN REFER TO WIRING DIAGRAM C4946

Appendix 3 – Exploded Views and Parts Lists

QUIETPACT™ 75D Recreational Vehicle Generator Intake and Exhaust System – Drawing No. C7656-A

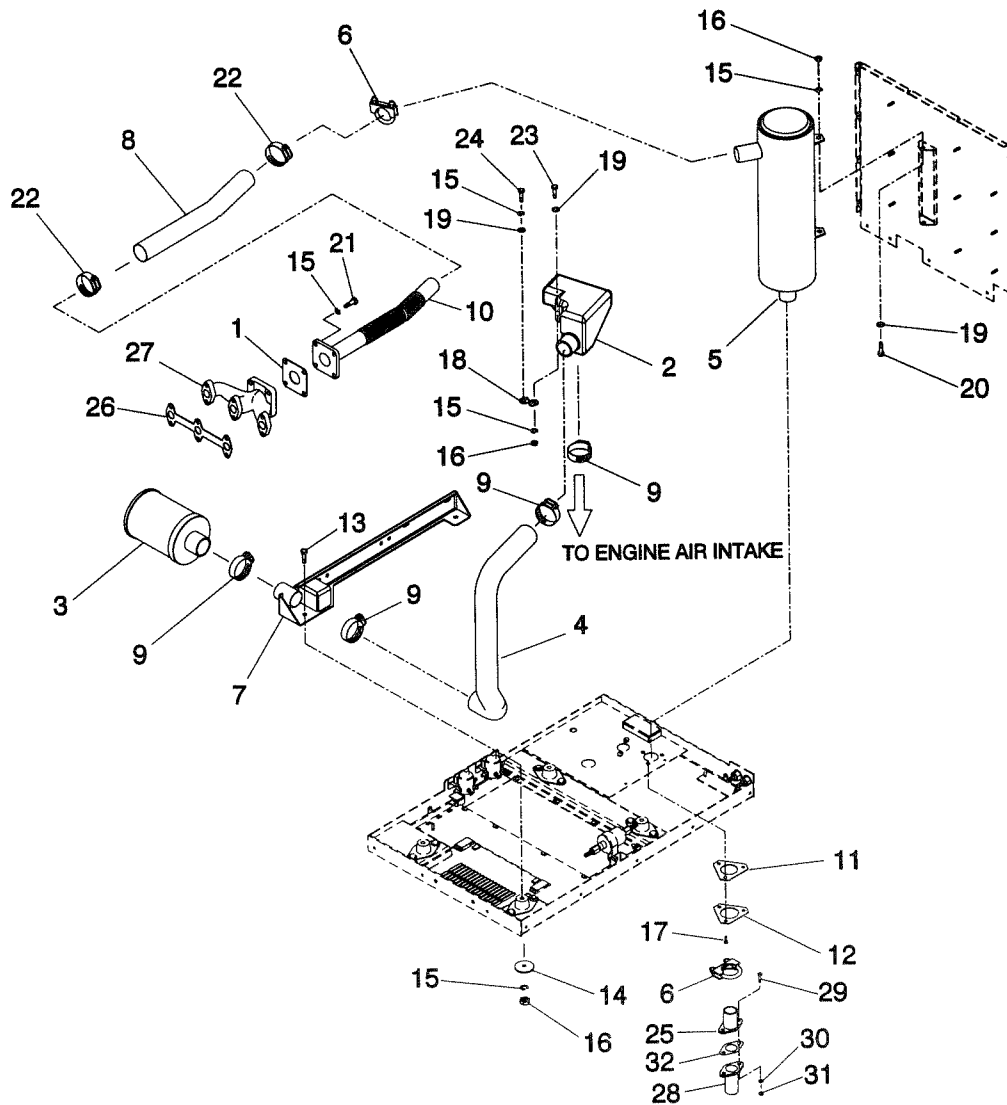
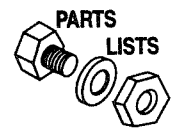

ITEM	PART NO.	QTY.	DESCRIPTION	ITEM	PART NO.	QTY.	DESCRIPTION
1	75674	1	EXHAUST GASKET	18	C5105	1	BRACKET, SUPPORT
2	C4879	1	CHAMBER AIR INTAKE	19	22145	4	WASHER, FLAT - M8
3	C4880	1	AIR FILTER	20	39253	2	HHCS M8-1.25 X 20
4	C5493	1	HOSE, AIR INLET	21	43107	4	HHCS M8-1.25 X 25
5	C4727	1	MUFFLER WELDMENT	22	35586	2	HOSE CLAMP #20
6	25145	2	U BOLT & SADDLE 1.25	23	42909	1	HHCS M8-1.25 X 30
7	C4539	1	RAIL, ENGINE LH, WELDMENT	24	42907	1	HHCS M8-1.25 X 16
8	C5022	1	INSULATION, EXHAUST	25	77642	1	ADAPTOR, EXHAUST FLANGE BOTTOM OUT
9	35685	4	HOSE CLAMP #28	26	357-70939	1	MANIFOLD GASKET
10	C4878	1	OUTLET, EXHAUST FLEX	27	75673	1	HORIZONTAL EXHAUST MANIFOLD
11	C6243	1	GASKET, EXHAUST OUTLET	28	A8543	1	ADAPTOR, UNIVERSAL EXHAUST
12	C6244	1	PLATE, EXHAUST OUTLET	29	68527	2	HHCS M6-1 X 20 W/LOCKWASHER
13	39288	2	HHCS M8-1.25 X 55	30	22097	2	WASHER, SPLIT LK M6
14	71956	2	WASHER, VIBRATION ISOLATOR	31	49813	2	NUT, HEX M6-1
15	22129	10	WASHER, SPLIT LK -M8	32	77643	1	GASKET, EXHAUST FLANGE
16	45771	5	NUT, HEX M8-1.25				
17	58443	3	CRIMPTITE, 1/4"-20 X 5/8"				

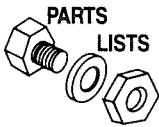

Appendix 3 – Exploded Views and Parts Lists

QUIETPACT™ 75D Recreational Vehicle Generator Fuel and Electrical Systems – Drawing No. C7657-A

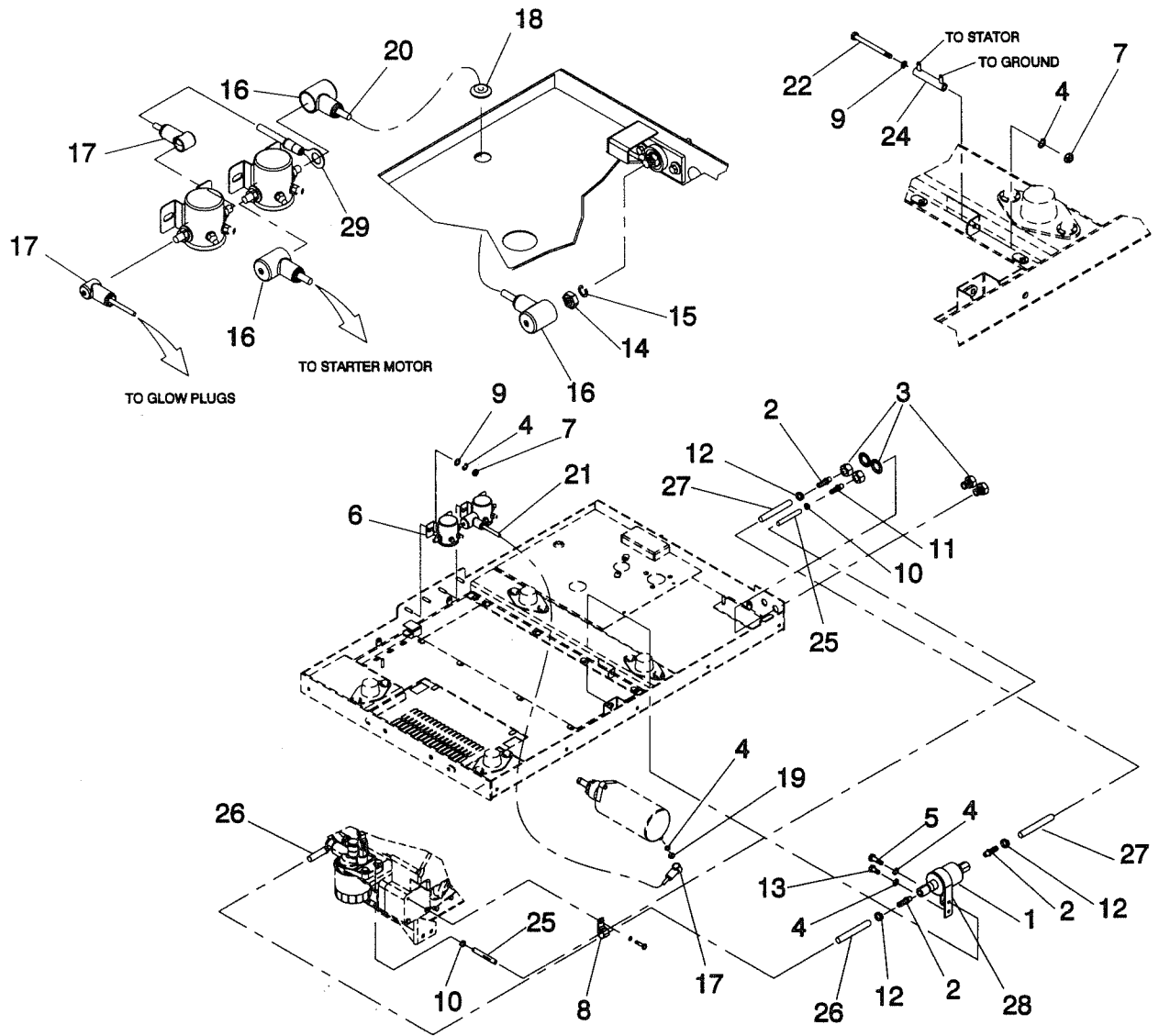

ITEM	PART NO.	QTY.	DESCRIPTION	ITEM	PART NO.	QTY.	DESCRIPTION
1	C6946A	1	FUEL PUMP ASSEMBLY	16	75763	3	BOOT, BATTERY CABLE
2	52219	3	1/8 NPT X 5/16 BARBED STRAIGHT FITTING	17	75763A	3	BOOT, BATTERY CABLE
3	69598B	2	BULKHEAD ADAPTOR FITTING	18	C7413	1	GROMMET 3/8 I/D X 1 GD
4	22097	7	WASHER, SPLIT LK- 1/4 -M6	19	22127	1	HEX NUT 1/4 - 20
5	38750	1	HHCS M6-1.00 X 30	20	20153621	1	CABLE, BATTERY
6	56739	2	RELAY SOLENOID	21	19753621	1	CABLE, STARTER
7	49813	5	NUT, HEX M6-1	22	A2053	1	HHCS M6-1 X 65
8	55934M	1	CLAMP, VINYL COAT 3/4	24	75234	1	RESISTOR
9	22473	5	WASHER, FLAT -M6	25	30340	1.04M	HOSE, 1/4 ID SAE-30R2
10	40173	2	HOSE CLAMP	26	C8008	635MM	HOSE, 5/16 ID SAE-30R7
11	28414A	1	1/8 NPT X 1/4 BARBED STRAIGHT FITTING	27	C8008	375MM	HOSE, 5/16 ID SAE-30R7
12	C7649	3	HOSE CLAMP 7/8 / 3/8	28	C8009	1	CLAMP, FUEL PUMP
13	47411	1	HHCS M6-1.00 X 16	29	C6712H	1	WIRE ASSY, #0 (PHC-SC)
14	76821	1	HEX NUT 3/8-16 BRASS				
15	22237	1	WASHER SPLIT LK 3/8				

M = METERS
MM = MILLIMETERS

Appendix 3 – Exploded Views and Parts Lists

**QUIETPACT™ 75D Recreational Vehicle Generator
1.0 Liter Diesel Camshaft – Drawing No. 75677**

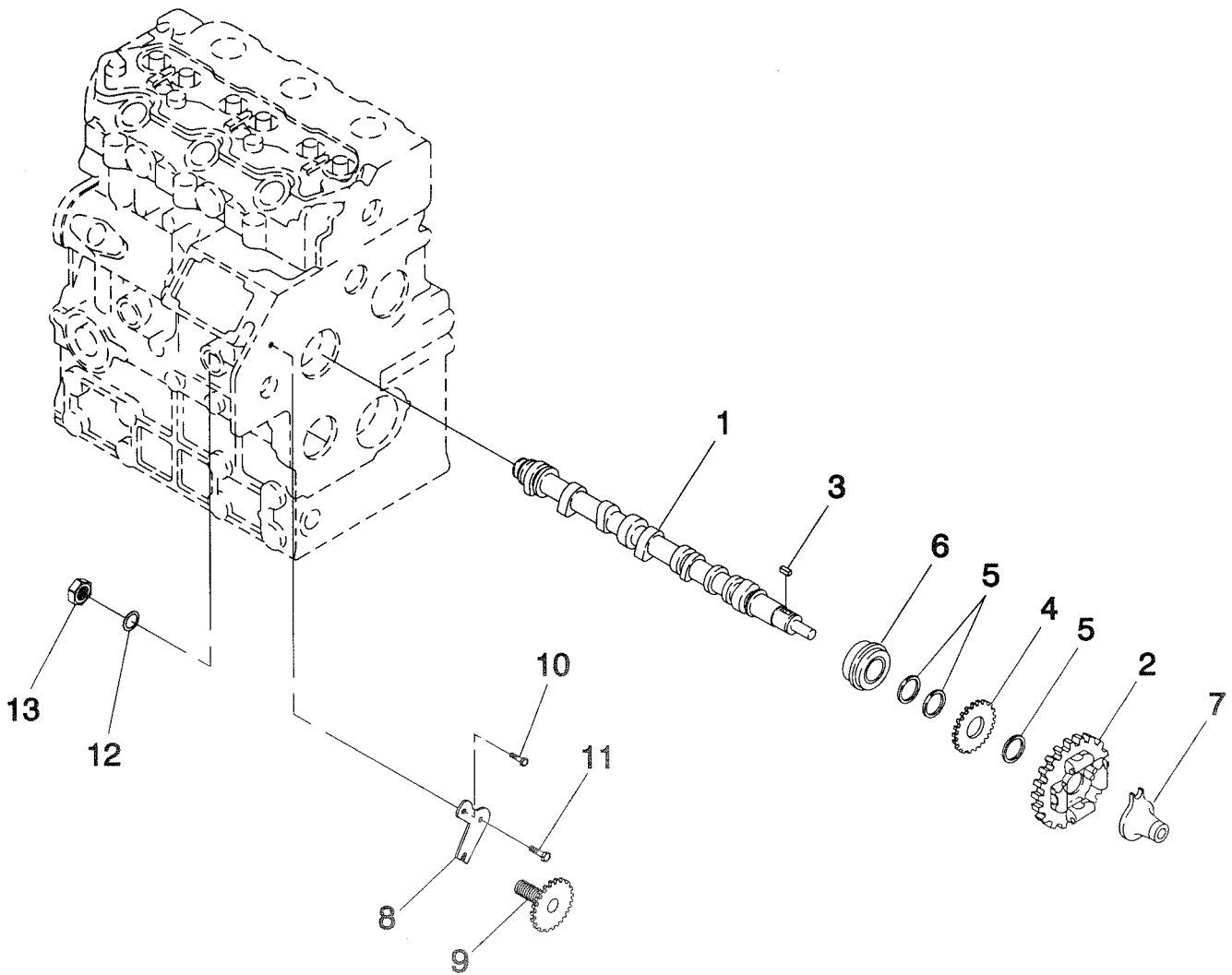
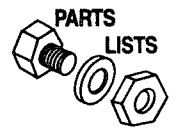

ITEM PART NO. QTY. DESCRIPTION

1	232-70939	1	CAMSHAFT ASSEMBLY
2	233-70939	1	CAMSHAFT GEAR
3	195-70939	1	KEY
4	234-70939	1	GEAR
5	235-70939	3	SPACER
6	236-70939	1	BALL BEARING
7	237-70939	1	SLIDER

ITEM PART NO. QTY. DESCRIPTION

8	238-70939	1	PLATE
9	239-70939	1	TACHOMETER SHAFT
10	240-70939	1	BOLT
11	241-70939	1	BOLT
12	242-70939	1	GASKET
13	243-70939	1	NUT

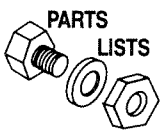

Appendix 3 – Exploded Views and Parts Lists

QUIETPACT™ 75D Recreational Vehicle Generator

1.0 Liter Diesel Cylinder Head – Drawing No. 75678-A

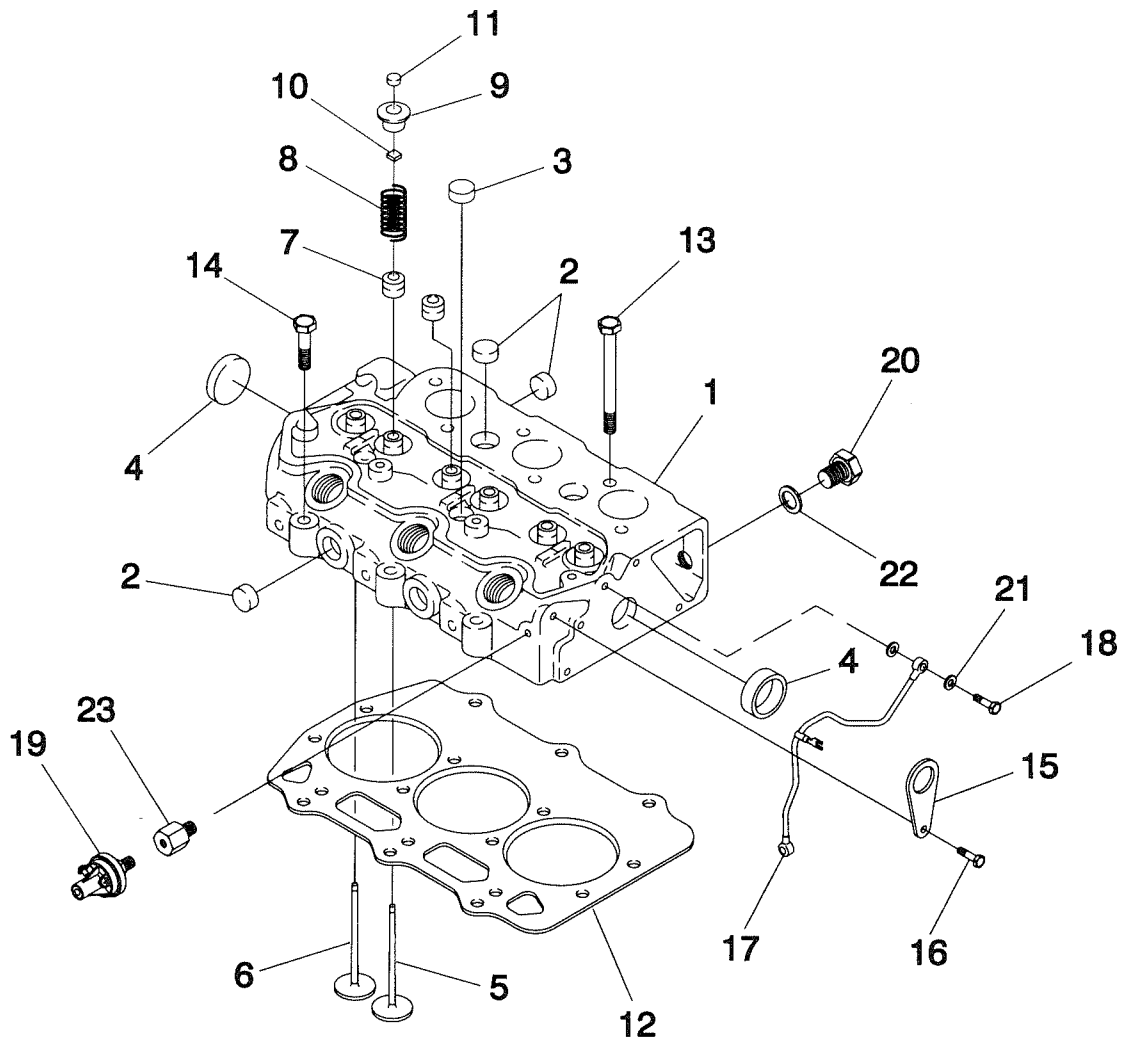

ITEM	PART NO.	QTY.	DESCRIPTION	ITEM	PART NO.	QTY.	DESCRIPTION
1	147-70939	1	CYLINDER HEAD ASSEMBLY	13	160-70939	11	BOLT
2	148-70939	6	EXPANSION PLUG	14	161-70939	3	BOLT
3	447-70939	3	EXPANSION PLUG	15	162-70939	2	LIFTING EYE
4	149-70939	2	EXPANSION PLUG	16	163-70939	2	BOLT
5	150-70939	3	INTAKE VALVE	17	164-70939	1	TUBING
6	151-70939	3	EXHAUST VALVE	18	165-70939	2	BOLT
7	152-70939	3	VALVE GUIDE SEAL (EXHAUST)	19	A8584	1	OIL SWITCH
	153-70939	3	VALVE GUIDE SEAL (INTAKE)	20	167-70939	1	THERMO-SWITCH (ALL MODELS EXCEPT 04270)
8	154-70939	6	SPRING		C8010	1	THERMO-SWITCH (MODEL 04270 ONLY)
9	155-70939	6	RETAINER	21	168-70939	4	GASKET
10	156-70939	12	KEY	22	169-70939	1	WASHER
11	157-70939	6	CAP	23	42574	1	ADAPTOR
12	158-70939	1	CYLINDER HEAD GASKET, 1.2MM THICK				
	159-70939	1	CYLINDER HEAD GASKET, 1.3MM THICK				

Appendix 3 – Exploded Views and Parts Lists

QUIETPACT™ 75D Recreational Vehicle Generator 1.0 Liter Diesel Crankshaft, Piston and Flywheel – Drawing No. 75679-A

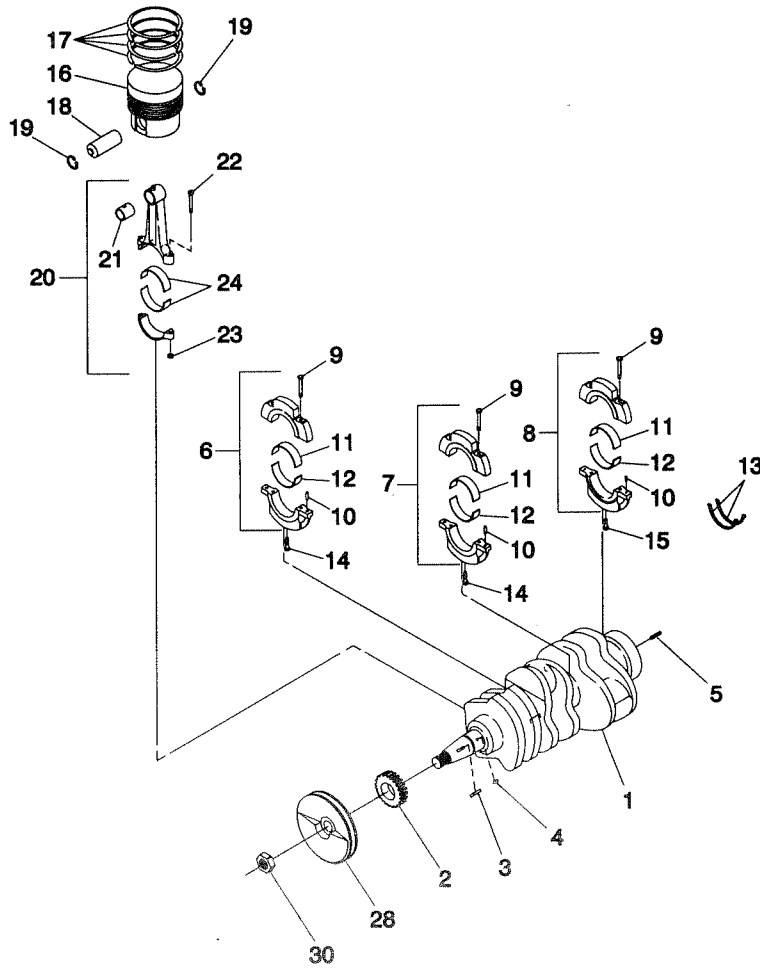
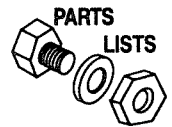

ITEM	PART NO.	QTY.	DESCRIPTION	ITEM	PART NO.	QTY.	DESCRIPTION
1	143-70939	1	CRANKSHAFT ASSEMBLY	16	214-70939	3	STANDARD PISTON ASSEMBLY
2	194-70939	1	CRANKSHAFT GEAR		215-70939	AR	PISTON ASSEMBLY-0.5MM O.S.
3	195-70939	1	KEY		216-70939	AR	PISTON ASSEMBLY-1.0MM O.S.
4	196-70939	1	DOWEL PIN	17	211-70939	3	STANDARD PISTON RING SET
5	226-70939	1	SPRING PIN		212-70939	AR	PISTON RING SET-0.5MM O.S.
6	197-70939	1	BEARING HOLDER ASSEMBLY		213-70939	AR	PISTON RING SET-1.0MM O.S.
7	200-70939	1	BEARING HOLDER ASSEMBLY	18	217-70939	3	PISTON PIN
8	664-70939	1	BEARING HOLDER ASSEMBLY	19	218-70939	6	SNAP RING
9	198-70939	6	BOLT	20	219-70939	3	CONNECTING ROD ASSEMBLY
10	199-70939	6	DOWEL PIN	21	220-70939	3	BUSHING
11	202-70939	3	STANDARD BEARING	22	221-70939	6	CONNECTING ROD BOLT
	203-70939	AR	0.25MM U.S. BEARING	23	222-70939	6	NUT, CONNECTING ROD BOLT
	204-70939	AR	0.50MM U.S. BEARING	24	223-70939	6	STANDARD BEARING
12	205-70939	3	STANDARD BEARING		224-70939	AR	BEARING-0.25MM U.S.
	206-70939	AR	0.25MM U.S. BEARING		225-70939	AR	BEARING-0.50MM U.S.
	207-70939	AR	0.50MM U.S. BEARING	28	230-70939	1	PULLEY
13	208-70939	2	THRUST WASHER	30	231-70939	1	NUT
14	204-70939	2	BOLT				
15	210-70939	1	BOLT				

U.S. - UNDERSIZE
O.S. - OVERSIZE
AR - AS REQUIRED
MM - MILLIMETER

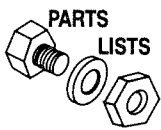

Appendix 3 – Exploded Views and Parts Lists

QUIETPACT™ 75D Recreational Vehicle Generator 1.0 Liter Diesel Oil Pump – Drawing No. 75682

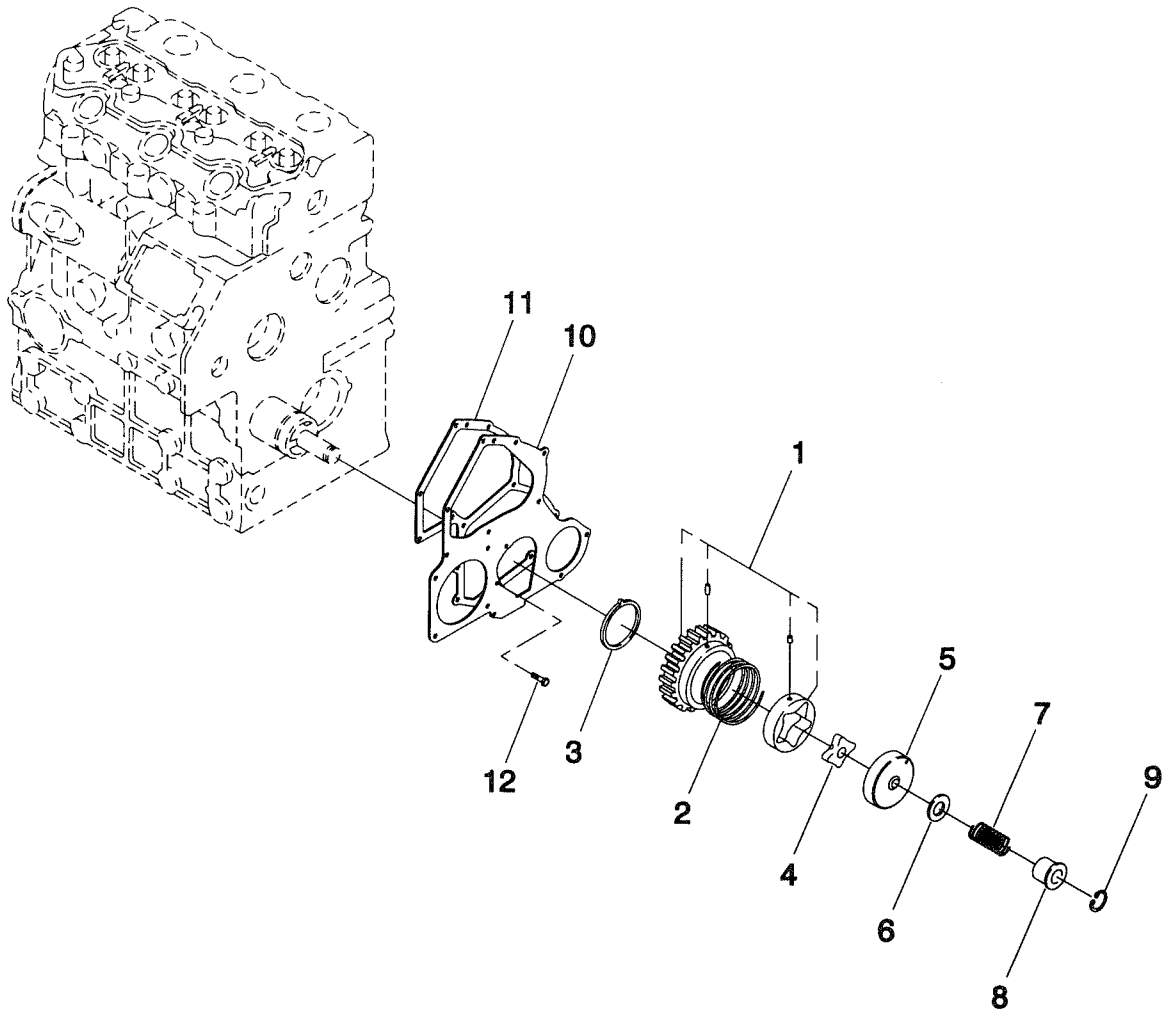

ITEM	PART NO.	QTY.	DESCRIPTION
1	250-70939	1	IDLER GEAR ASSEMBLY
2	252-70939	1	SPRING
3	251-70939	1	THRUST WASHER
4	253-70939	1	ROTOR
5	254-70939	1	OIL PUMP COVER
6	255-70939	AR	0.10MM SHIM
	532-70939	AR	0.15MM SHIM
	533-70939	AR	0.20MM SHIM
	258-70939	AR	0.50MM SHIM

ITEM	PART NO.	QTY.	DESCRIPTION
7	259-70939	1	SPRING
8	260-70939	1	COLLAR
9	261-70939	1	SNAP RING
10	262-70939	1	FRONT PLATE
11	263-70939	1	GASKET
12	264-70939	3	BOLT

AR - AS REQUIRED

Appendix 3 – Exploded Views and Parts Lists
QUIETPACT™ 75D Recreational Vehicle Generator
1.0 Liter Diesel Rocker Arm Assembly – Drawing No. 75683

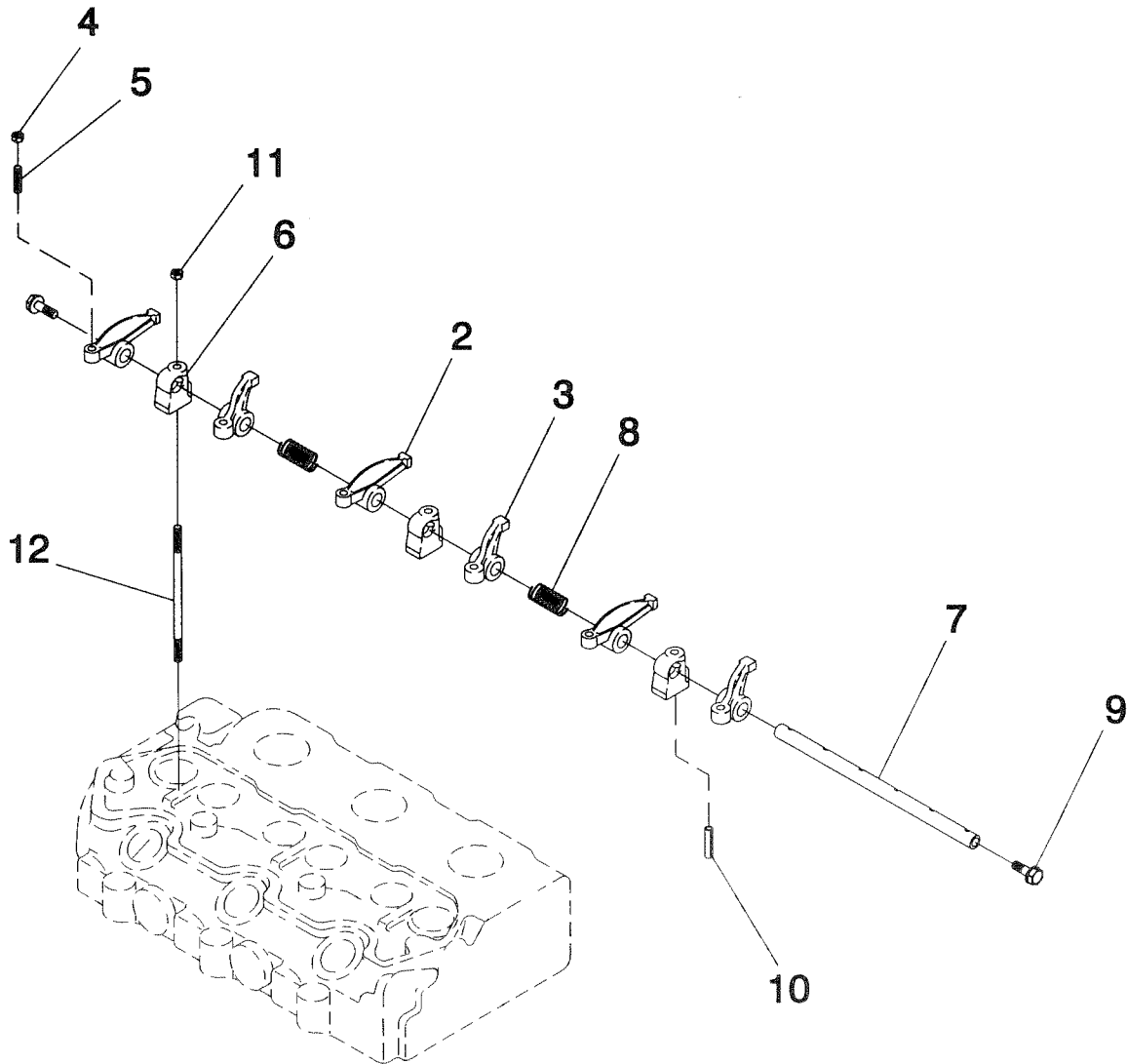
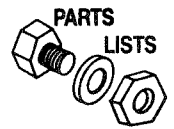

ITEM	PART NO.	QTY.	DESCRIPTION
1	170-70939	1	ROCKER ARM ASSEMBLY
2	171-70939	3	INTAKE ROCKER ARM
3	172-70939	3	EXHAUST ROCKER ARM
4	174-70939	6	NUT
5	173-70939	6	STUD
6	175-70939	3	ROCKER ARM BRACKET

ITEM	PART NO.	QTY.	DESCRIPTION
7	176-70939	1	ROCKER ARM SHAFT
8	177-70939	2	SPRING
9	178-70939	2	SCREW
10	179-70939	3	SPRING,PIN
11	180-70939	3	NUT
12	181-70939	3	STUD

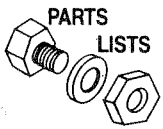

Appendix 3 – Exploded Views and Parts Lists

QUIETPACT™ 75D Recreational Vehicle Generator

1.0 Liter Diesel Injector Pump – Drawing No. 75686-B

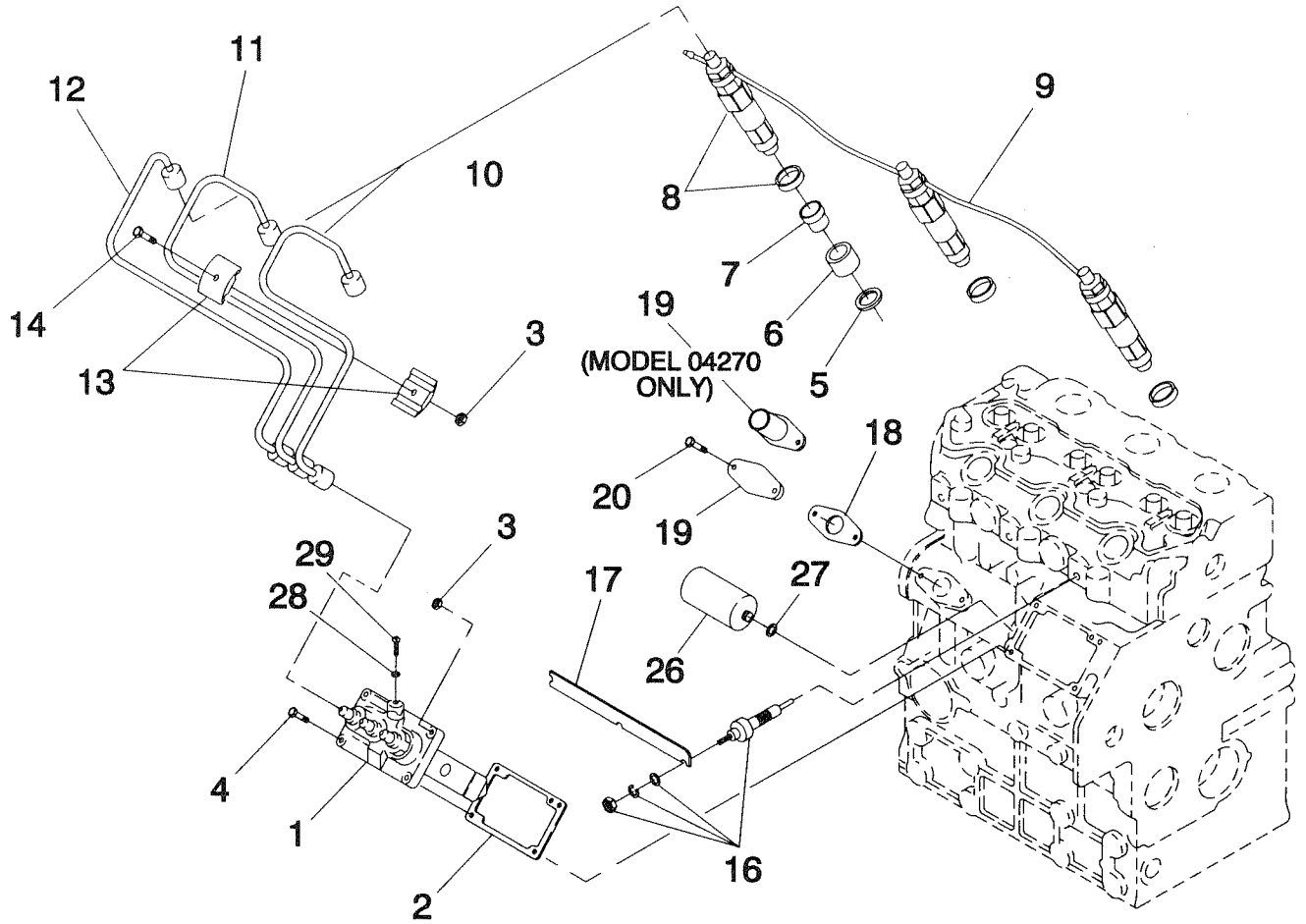

ITEM	PART NO.	QTY.	DESCRIPTION	ITEM	PART NO.	QTY.	DESCRIPTION
1	316-70939	1	INJECTOR PUMP ASSEMBLY	13	330-70939	1	CLAMP
2	317-70939	AR	SHIM-0.2MM	14	331-70939	1	BOLT
	318-70939	AR	SHIM-0.3MM	16	332-70939	3	GLOW PLUG
	319-70939	AR	SHIM-0.5MM	17	333-70939	1	CONNECTOR
	320-70939	AR	SHIM-1.0MM	18	334-70939	1	GASKET
3	298-70939	3	NUT	19	335-70939	1	COVER
4	321-70939	2	BOLT				(ALL MODELS EXCEPT 04270)
5	322-70939	3	GASKET	C4736		1	TUBE, ENGINE OIL FILL
6	323-70939	3	INSERT				(MODEL 04270 ONLY)
7	324-70939	3	CAP	20	264-70939	2	BOLT
8	325-70939	3	INJECTOR	26	341-70939	1	SOLENOID
9	326-70939	1	TUBING	27	342-70939	1	WASHER
10	327-70939	1	TUBING	28	343-70939	1	WASHER
11	328-70939	1	TUBING	29	344-70939	1	SCREW
12	329-70939	1	TUBING				

AR - AS REQUIRED

Appendix 3 – Exploded Views and Parts Lists

QUIETPACT™ 75D Recreational Vehicle Generator 1.0 Liter Diesel Fuel Supply – Drawing No. 75693-A

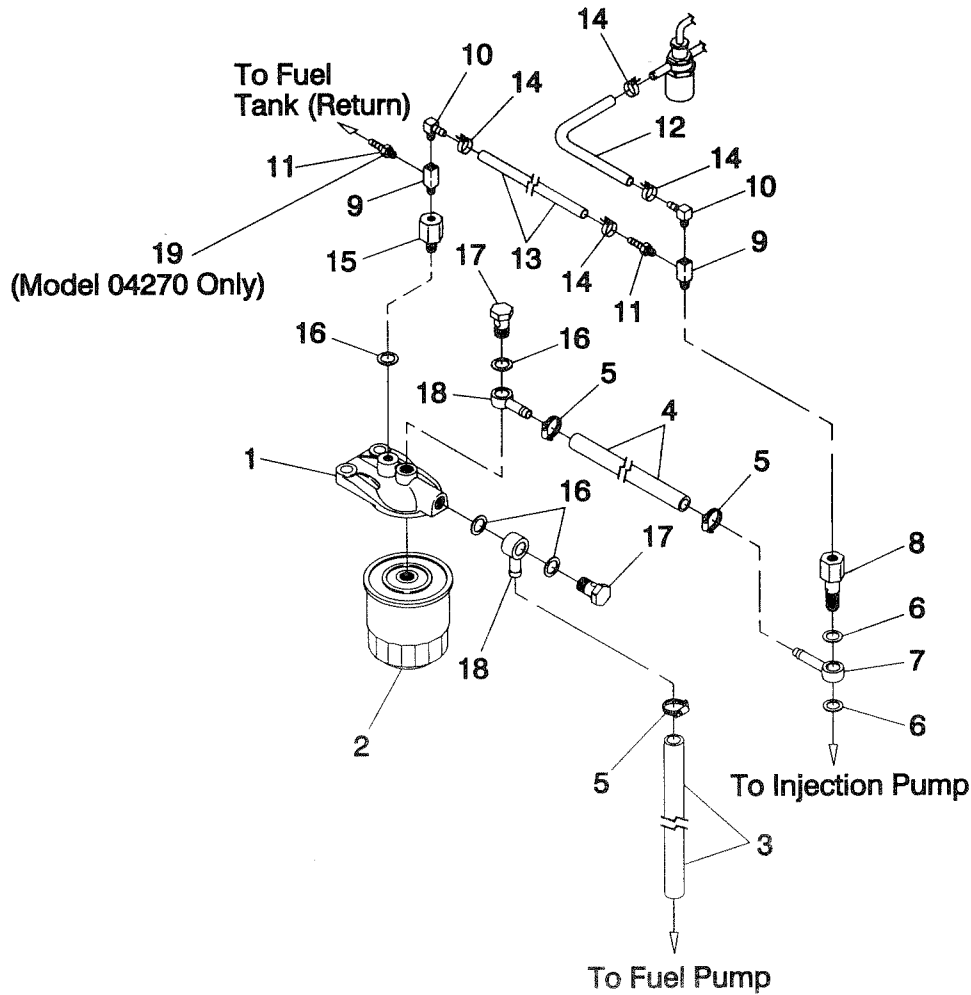
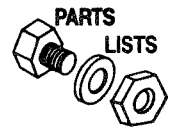

ITEM	PART NO.	QTY.	DESCRIPTION	ITEM	PART NO.	QTY.	DESCRIPTION
1	661-70939	1	FUEL FILTER SUPPORT	11	30096	2*	1/8" NPT X 3/16" BARBED STRAIGHT FITTING
2	69858	1	FUEL FILTER	12	68736	275MM	HOSE, 3/16" SAE 30R2
3	C8008	AR	HOSE, 5/16" SAE 30R7	13	68736	240MM	HOSE, 3/16" SAE 30R2
4	C8008	250MM	HOSE, 5/16" SAE 30R7	14	74823	4	HOSE CLAMP
5	40173	3	HOSE CLAMP	15	74819	1	FUEL BLEED FITTING
6	378-70939	2	GASKET	16	651-70939	5	FUEL BLEED GASKET
7	379-70939	1	BANJO FITTING	17	662-70929	2	HOLLOW BOLT
8	74808	1	FUEL BLEED FITTING	18	663-70939	2	BANJO FITTING
9	52233	2	1/8" NPT TEE (BRASS)	19	28414A	1	1/8" NPT X 1/4" BARBED STRAIGHT FITTING (MODEL 04270 ONLY)
10	39450	2	1/8" NPT X 3/16" 90 DEG. BARBED FITTING				

* -QTY 1 (MODEL 04270 ONLY)
AR - AS REQUIRED

Appendix 3 – Exploded Views and Parts Lists
QUIETPACT™ 75D Recreational Vehicle Generator
1.0 Liter Diesel Timing and Governor – Drawing No. 82067

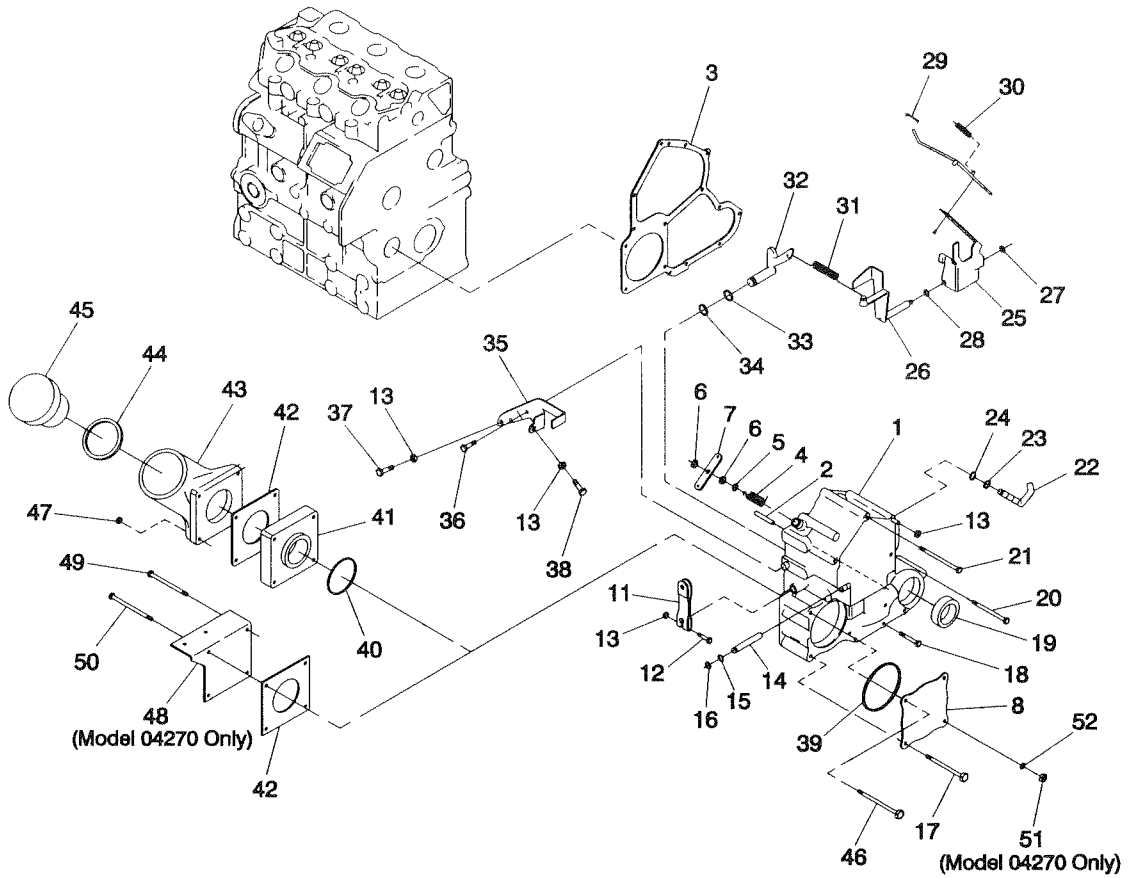

ITEM	PART NO.	QTY.	DESCRIPTION	ITEM	PART NO.	QTY.	DESCRIPTION
1	285-70939	1	TIMING GEAR HOUSING	30	313-70939	1	SPRING
2	286-70939	1	SPRING PIN	31	293-70939	1	SPRING
3	287-70939	1	GASKET	32	294-70939	1	ARM
4	307-70939	1	SPRING	33	295-70939	1	O-RING
5	308-70939	1	WASHER	34	291-70939	1	SNAP RING
6	309-70939	2	NUT	35	302-70939	1	BRACKET
7	310-70939	1	STOP LEVER	36	271-70939	3	BOLT
8	314-70939	2	COVER	37	303-70939	2	BOLT
11	296-70939	1	GOVERNOR LEVER	38	71944	1	HHCS M6-1.0 X 25MM
12	297-70939	1	BOLT	39	660-70939	1	O-RING
13	298-70939	1	NUT	40	534-70939	1 *	O-RING
14	299-70939	1	SHAFT	41	535-70939	1 *	SPACER
15	300-70939	1	O-RING	42	536-70939	1	GASKET
16	301-70939	1	SNAP RING	43	537-70939	1 *	HOLDER (OIL FILL)
17	540-70939	3 *	BOLT	44	539-70939	1 *	O-RING
18	282-70939	5	BOLT	45	188-70939	1 *	CAP
19	288-70939	1	OIL SEAL	46	541-70939	1 *	BOLT
20	274-70939	4	BOLT	47	538-70939	3 *	NUT
21	311-70939	5	BOLT	48	C4888	1	BRACKET, FUEL FILTER (MODEL 04270 ONLY)
22	304-70939	1	ARM	49	51730	3	BOLT (MODEL 04270 ONLY)
23	305-70939	1	SNAP RING	50	52265	1	BOLT (MODEL 04270 ONLY)
24	306-70939	1	O-RING	51	45771	4	NUT (MODEL 04270 ONLY)
25	289-70939	1	GOVERNOR LEVER ASSEMBLY	52	22129	4	SPLIT LOCK WASHER M8 (MODEL 04270 ONLY)
26	290-70939	1	TENSION LEVER				
27	291-70939	1	SNAP RING				
28	136-70939	1	WASHER				
29	292-70939	1	COTTER PIN				

* NOT USED ON MODEL 04270

Appendix 3 – Exploded Views and Parts Lists
QUIETPACT™ 75D Recreational Vehicle Generator
1.0 Liter Diesel Engine Block – Drawing No. 82961-A

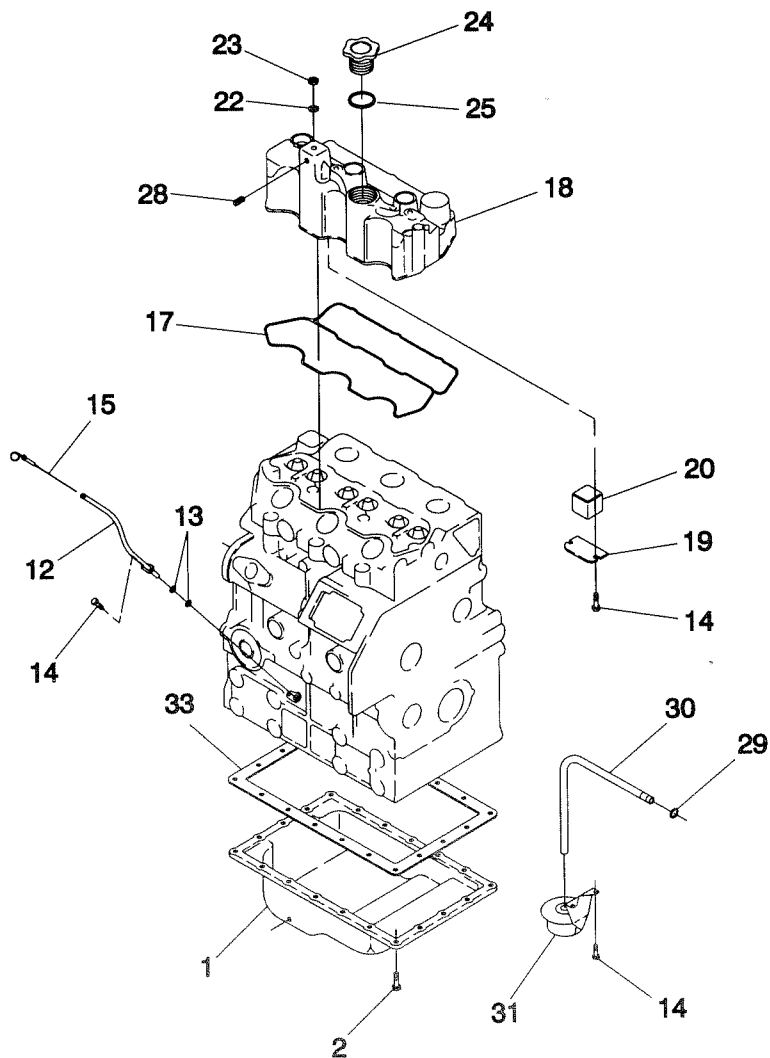
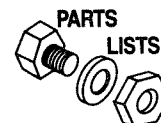

ITEM	PART NO.	QTY.	DESCRIPTION	ITEM	PART NO.	QTY.	DESCRIPTION
1	139-70939	1	OIL PAN	19	185-70939	1	OIL STOPPER
2	140-70939	20	BOLT	20	186-70939	1	SCREEN
12	143-70939	1	DIPSTICK TUBE (ALL MODELS EXCEPT 04270)	22	168-70939	1	GASKET
	C4641	1	DIPSTICK TUBE (MODEL 04270 ONLY)	23	187-70939	3	NUT
13	144-70939	2	O-RING	24	188-70939	1	CAP
14	145-70939	5	BOLT	25	189-70939	1	O-RING
15	146-70939	1	DIPSTICK (ALL MODELS EXCEPT 04270)	28	26073-A	1	1/4" PIPE PLUG SQ. HD.
17	183-70939	1	ROCKER COVER GASKET	29	244-70939	1	O-RING
18	184-70939	1	ROCKER COVER	30	245-70939	1	TUBING
				31	246-70939	1	SUCTION FILTER
				33	122-70939	1	GASKET

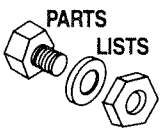

Appendix 3 – Exploded Views and Parts Lists
QUIETPACT™ 75D Recreational Vehicle Generator
1.0 Liter Diesel Water Pump – Drawing No. 82962

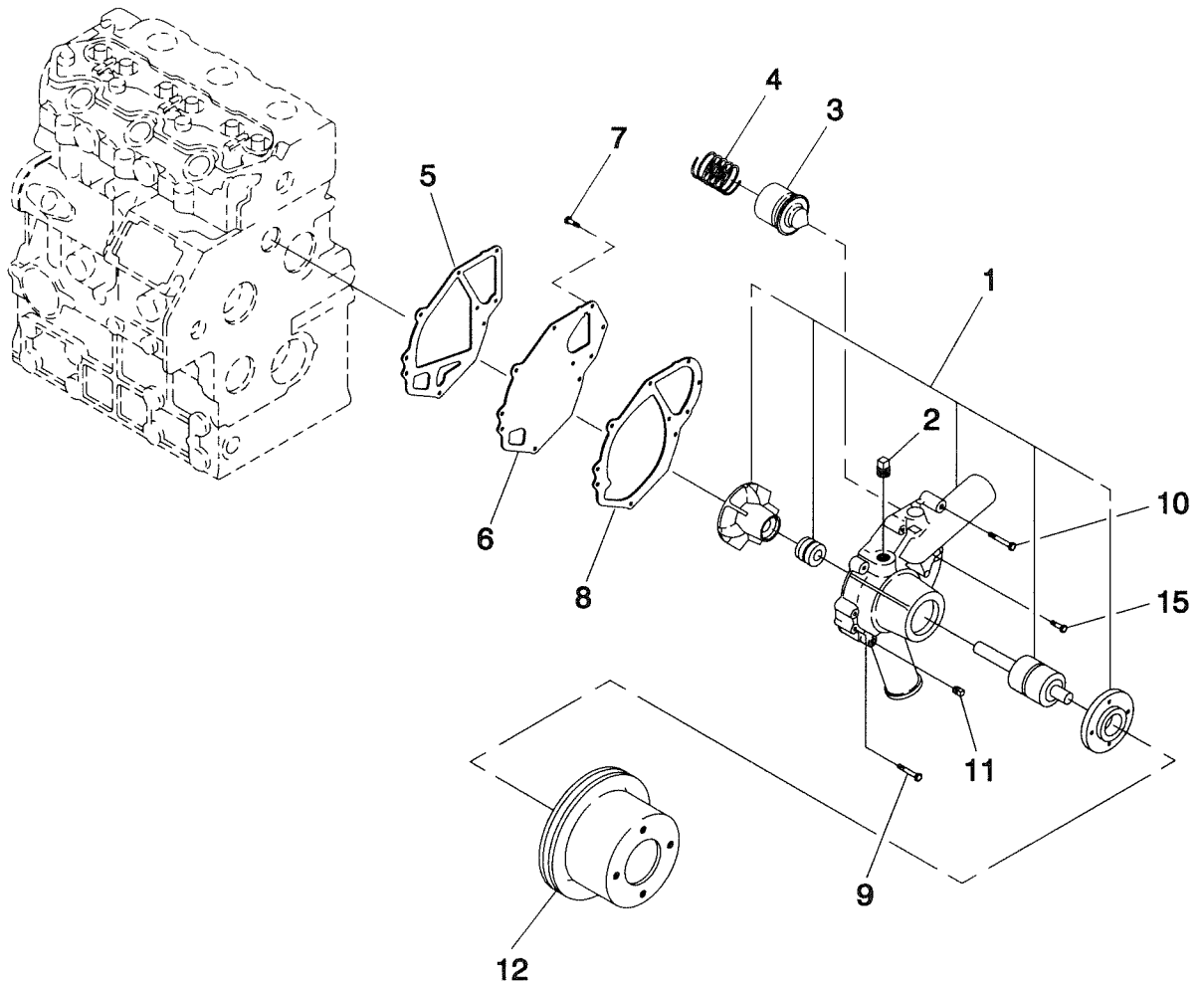

ITEM	PART NO.	QTY.	DESCRIPTION
1	265-70939	1	WATER PUMP ASSEMBLY
2	266-70939	1	PLUG
3	267-70939	1	THERMOSTAT
4	268-70939	1	SPRING
5	269-70939	3	GASKET
6	270-70939	1	SET PLATE
7	271-70939	1	BOLT

ITEM	PART NO.	QTY.	DESCRIPTION
8	272-70939	1	GASKET
9	273-70939	1	BOLT
10	274-70939	1	BOLT
11	275-70939	1	NUT
12	247-70939	1	PULLEY
15	284-70939	1	BOLT

Lined area for notes, consisting of numerous horizontal lines.



FEDERAL AND CALIFORNIA EMISSIONS CONTROL WARRANTY STATEMENT

(for non-road Diesel engines rated under 19 kW)

YOUR WARRANTY RIGHTS AND OBLIGATIONS

The U.S. Environmental Protection Agency (EPA), the California Air Resources Board (CARB), Generac Power Systems, Inc. (GENERAC) and the engine manufacturer for this equipment, Ishikawajima Shibaura Machinery Co., Ltd. (ISM), are pleased to explain the federal and California emission control system warranty on your engine.

In California, new 2000 and later small non-road engines must be designed, built and equipped to meet the state's stringent anti-smog standards. In other states, new 2000 and later non-road diesel engines rated under 19 kW must be designed, built and equipped to conform to applicable EPA regulations.

ISM must warrant the emission control system on your engine for that period of time listed below provided there has been no abuse, neglect or improper maintenance of your small non-road diesel engine.

Your California and EPA emission control system may include parts such as the fuel injection system and other emission-related assemblies.

Where a warrantable condition exists, GENERAC will repair your engine at no cost to you, including diagnosis, parts and labor, on behalf of ISM. Although ISM is ultimately responsible for this warranty, GENERAC has agreed to carry out ISM's warranty repair responsibilities, and GENERAC should be your primary contact for emission-related warranty service.

MANUFACTURER'S WARRANTY COVERAGE

For 2000 and later small non-road diesel engines first sold in California, and 2000 and later non-road diesel engines rated under 19 kW first sold in all other states, the applicable warranty period is two (2) years or 1,500 hours, whichever comes first.

If any emission-related part on your engine is defective, the part will be repaired or replaced by a Generac Authorized Warranty Service Facility on behalf of ISM.

PARTS COVERED

This emission control system warranty applies to the following engine emission control parts.

- Fuel Injection Pump
- Intake Manifold
- Air Cleaner Element
- Fuel Injectors
- Exhaust Manifold
- Miscellaneous Hoses, Bolts and Connectors

OWNER'S WARRANTY RESPONSIBILITIES

As the engine owner, you are responsible for the performance of the required maintenance listed in your *Owner's Manual*. GENERAC and ISM recommend that you retain the original purchase documentation and all receipts covering maintenance on your engine, but GENERAC and ISM cannot deny warranty solely for the lack of receipts or for your failure to ensure the performance of all scheduled maintenance.

As the engine owner, you should be aware, however, that GENERAC and ISM may deny you warranty coverage if your engine or a part has failed due to abuse, neglect, improper maintenance or unapproved modifications.

You are responsible for contacting a Generac Authorized Warranty Service Facility as soon as a problem occurs. The warranty repairs should be completed in a reasonable amount of time, not to exceed 30 days.

Warranty Service can be arranged by contacting either your selling dealer or a Generac Authorized Warranty Service Facility. To locate the Generac Authorized Warranty Service Facility nearest you, call our toll-free number:

1-800-333-1322

If you have any questions regarding your warranty rights and responsibilities, you should contact GENERAC at the following address:

**ATTENTION WARRANTY DEPARTMENT
GENERAC POWER SYSTEMS, INC.
211 MURPHY DRIVE
EAGLE, WI 53119**



OBLIGATIONS AND RIGHTS OF THE MANUFACTURER AND OWNER

The new model year, class of diesel engine, and emission application determination for your engine are identified on the emission control information label affixed to the right-hand side of your engine's timing gear case. The warranty period begins on the date the new equipment is sold to the first retail purchaser.

Any emission control system parts scheduled for regular inspection that are proven defective during normal use will be repaired or replaced during the warranty period. Any warranted part that is scheduled for replacement and that fails prior to replacement will be repaired or replaced under warranty, and the repaired or replaced part will be covered under warranty for the remainder of the period prior to the first scheduled replacement. The warranty repairs and service will be performed by any Generac Authorized Warranty Service Facility, with no charge for parts or labor (including diagnosis).

As the engine owner, you are responsible to perform all the required maintenance listed in your *Owner's Manual*. GENERAC will not deny an emission warranty claim solely because you have no record of maintenance; however, a claim may be denied if your failure to perform maintenance resulted in the failure of a warranted part. Receipts covering regular maintenance should be retained in the event of questions, and these receipts should be passed on to each subsequent owner of the engine.

It is recommended that replacement parts used for maintenance or repairs be GENERAC authorized and approved parts to maintain the quality originally designed into your emission certified engine. However, any replacement part may be used in the performance of any warranty maintenance or repairs and must be provided without charge to the owner. Such use will not reduce the warranty obligations of GENERAC. Add-on or modified parts may not be used for maintenance or warranty repairs. Such use will be grounds for disallowing a warranty claim, and GENERAC will not be liable to warrant failures of warranted parts caused by the use of an add-on or modified part.

LIMITATIONS

This warranty shall not cover any of the following:

- (a) Systems and parts that were not first installed on the new equipment or engine as original equipment by GENERAC.
- (b) Conditions resulting from tampering, misuse, abuse, improper adjustment, engine alteration, use of add-on or modified parts, use of replacement parts that are not the same in performance and durability as GENERAC-approved replacement parts, accident, failure to use the recommended fuel or oil, use of unapproved fuel or oil additives, or failure to perform required maintenance.
- (c) Replacement parts used for required or scheduled maintenance.
- (d) Consequential damages such as loss of time, inconvenience, or loss of use of this engine or equipment.
- (e) Damages or repair costs caused by the owner's unreasonable delay in making the engine available for inspection and repair.
- (f) Diagnosis or inspection fees that do not result in eligible warranty service being performed.
- (g) Equipment with an altered or disconnected hourmeter where the hours cannot be determined.
- (h) Equipment normally operated outside the United States.
- (i) Accident-caused damage, acts of nature, or other events beyond GENERAC'S control.
- (j) Warranty repairs undertaken or attempted by the owner or any other person who is not affiliated with a Generac Authorized Warranty Service Facility.

OBTAINING WARRANTY SERVICE

To obtain service under this warranty, promptly contact your nearest Generac Authorized Service Dealer or a Generac Authorized Warranty Service Facility. If available, provide the GENERAC representative with the original purchase receipt (showing the initial date of purchase) and all available maintenance records.



Appendix 5 – Warranty

QUIETPACT™ 75D Recreational Vehicle Generator

GENERAC POWER SYSTEMS' THREE-YEAR LIMITED WARRANTY FOR RECREATIONAL VEHICLE GENERATORS

NOTE: ALL UNITS MUST BE INSTALLED BY GENERAC POWER SYSTEMS AUTHORIZED SERVICE FACILITIES. For a period of 3 (three) years or 2,000 (two thousand) hours of operation from the date of original sale, whichever occurs first, Generac Power Systems, Inc. (Generac) will, at its option, repair or replace any part which, upon examination, inspection, and testing by Generac or a Generac Authorized Warranty Service Facility, is found to be defective under normal use and service, in accordance with the warranty schedule set forth below. Any equipment that the purchaser/owner claims to be defective must be returned to and examined by the nearest Generac Authorized Warranty Service Facility. All transportation costs under the warranty, including return to the factory, are to be borne and prepaid by the purchaser/owner. This warranty applies only to Generac generators sold and rated for "Recreational Vehicle" (RV) applications, as Generac has defined Recreational Vehicle generator applications. This warranty is effective only upon Generac's receipt, from the original purchaser/owner, of a completed Warranty Registration Card. This card is the only valid registration identification and must be presented at time of request for warranty service. Claims will not be accepted without presentation of the Warranty Registration Card. The factory recommends exercising the unit one half-hour every season.

WARRANTY SCHEDULE – COMMERCIAL APPLICATIONS

YEAR ONE – 100% (one hundred percent) coverage on part(s), labor, removal, and reinstallation listed:

- **Engine** – All components
- **Alternator** – All components
- **Transfer System** – All components

WARRANTY SCHEDULE – CONSUMER/PERSONAL APPLICATIONS

YEARS ONE AND TWO – 100% (one hundred percent) coverage on part(s), labor, removal, and reinstallation listed:

- **Engine** – All components
- **Alternator** – All components
- **Transfer System** – All components

YEAR Three – 100% (one hundred percent) only on selected part(s) and labor listed (Any labor and part(s) not listed, and removal and reinstallation, are the owner's responsibility):

- Rotor, Stator, Computer Control Board, (if applicable with regard to the generator) Cylinder Block, Cylinder Head, Crankshaft, Piston(s), Valve, Valve Lifter(s), Intake and Exhaust Manifolds

FOR THE LIFE OF THE RECREATIONAL VEHICLE GENERATOR (IF SO EQUIPPED)

The drive train belt and pulleys (excluding tensioners) on generators used in recreational vehicles shall be warranted against failure due to defective materials or normal usage for the life of the generator. For the original purchaser/owner, this drive train warranty shall include part(s) and labor (removal and reinstallation are not included), plus \$50 (fifty dollars – U.S.) payment upon return of the failed belt or pulley by the original purchaser/owner. For subsequent purchaser/owner, this drive train warranty shall cover belt and pulley part(s) **ONLY** (labor not included). Labor, removal, and reinstallation are the responsibility of the subsequent purchaser/owner.

Generac RV generators manufactured prior to December 31, 1997, **DO NOT** have a transferable warranty. Generac RV generators manufactured after January 1, 1998, have a transferable warranty to the second owner, **ONLY** for the remainder of the three-year limited warranty. Proof of purchase is required and must be presented to a Generac Authorized Warranty Service Facility prior to the performance of any warranty service.

All warranty expense allowances **are** subject to the conditions defined in Generac's **SUPER SERVICE INFORMATION MANUAL**.

THIS WARRANTY SHALL NOT APPLY TO THE FOLLOWING:

- Costs of normal maintenance, adjustments, installation, and startup.
- Failures caused by any contaminated fuels or oils.
- Failures due, but not limited, to normal wear and tear, accident, misuse, abuse, negligence or improper installation. As with all mechanical devices, engines need periodic part(s) service and replacement to perform well. This warranty will not cover repair when normal use has exhausted the life of a part(s) or engine.
- Failures caused by any external cause or act of God, such as, collision, theft, vandalism, riot or wars, nuclear holocaust, fire, freezing, lightning, earthquake, windstorm, hail, volcanic eruption, water or flood, tornado or hurricane.
- Products that are modified or altered in a manner not authorized by Generac in writing.
- Any incidental, consequential, or indirect damages caused by defects in materials or workmanship, or any delay in repair or replacement of the defective part(s).
- Failure due to misapplication.
- Telephone, telegraph, teletype or other communication expenses.
- Living or travel expenses of person(s) performing service, except as specifically included within the terms of a specific unit warranty period.
- Rental equipment used while warranty repairs are being performed.
- Overnight freight costs for replacement part(s).
- Overtime labor.
- Starting batteries, fuses, light bulbs, and engine fluids.

THIS WARRANTY IS IN PLACE OF ALL OTHER WARRANTIES, EXPRESSED OR IMPLIED. SPECIFICALLY, GENERAC MAKES NO OTHER WARRANTIES AS TO THE MERCHANTABILITY OR FITNESS FOR A PARTICULAR PURPOSE. Some states do not allow limitations on how long an implied warranty lasts, so the above limitation may not apply to you.

GENERAC'S ONLY LIABILITY SHALL BE THE REPAIR OR REPLACEMENT OF PART(S), AS STATED ABOVE. IN NO EVENT SHALL GENERAC BE LIABLE FOR ANY INCIDENTAL OR CONSEQUENTIAL DAMAGES, EVEN IF SUCH DAMAGES ARE A DIRECT RESULT OF GENERAC'S NEGLIGENCE. Some states do not allow the exclusion or limitation of incidental or consequential damages, so the above limitation may not apply to you. Purchaser/owner agrees to make no claims against Generac based on negligence.

This warranty gives you specific legal rights. You also may have other rights that vary from state to state.

GENERAC® POWER SYSTEMS, INC.
P.O. BOX 8 · WAUKESHA, WI 53187